

Agenda

Historic District Commission

City of Kalamazoo



Tuesday, April 15, 2025

5:00 PM

City Commission Chambers at City Hall – 241 West South Street

A. CALL TO ORDER/ROLL CALL

1. Kristi Breisach
2. Katie Boertman
3. James Johnson
4. Dan Kastner - Chair
5. Eric Stucky
6. Dana Underwood - Vice-Chair

B. ADOPTION OF FORMAL AGENDA

C. APPROVAL OF MINUTES

1. Approval of the minutes from the Historic District Commission meeting on 18 March 2025

D. PUBLIC COMMENTS

E. APPLICATION REVIEWS

1. 430 Elm - New Construction (Construction of detached garage) PPZ25-0007
Year Built: 1860
Style: Italianate
Historic District: Stuart
2. 107 (107, 109, 111), 115 and 119 (non-contributing) W Vine - Demolition (Demolition of 5 buildings) PPZ25-0008
Year Built: 1912, 1875, 1914 (107); 1885 (115); 1970 (119)
Style: Colonial Revival, Italianate, Colonial Revival (107); Italianate (115); Contemporary (119)
Historic District: South Street - Vine Area
3. 807 W Vine - Alteration (Replacement of windows) - PPZ24-0035
Year Built: 1915
Style: Tudor Revival

Historic District: South Street - Vine Area

F. COORDINATOR'S REPORT

1. Coordinator's Report

G. ADJOURNMENT

DISCLAIMER

Chapter 16, Section 22 of the City of Kalamazoo Code of Ordinance states:

Historical preservation is a public purpose. To serve that purpose, the Historic District Commission is hereby charged with the following responsibilities:

- a) The Kalamazoo Historic District Commission is empowered to regulate Work on the exterior of historic resources and non-historic resources in historic districts in the City of Kalamazoo and shall otherwise have all powers invested in Historic District Commissions pursuant to the Local Historic Districts Act, MCLA § 399.201 et seq. 1970 PA 169, as Amended 1992.
- b) To regulate Work on resources which, by City ordinance, are historic or non-historic resources located within local historic districts, including but not limited to the moving of any structure into or out of, or the building of any structure in, an historic district.

The following documents are available in the Community Planning and Economic Development Department located at 245 North Rose Street. These documents will help assist property owners in understanding the responsibilities of owning property in a local historic district: MCLA § 399.201 et seq. 1970 PA 169 as Amended 1992 (Michigan Local Historic District Act); Code of Ordinances City of Kalamazoo, Michigan (Chapter 16 - Historic District); Secretary of the Interiors Standards for Rehabilitation & Guidelines for Rehabilitating Historic Buildings, 1990; Standards and Guidelines for Kalamazoo Historic Districts, and maps of Kalamazoo Local Historic Districts. These documents and maps are also available on the city of Kalamazoo website at www.kalamazoocity.org/historicpreservation.

GUIDELINES FOR PUBLIC PARTICIPATION AT HDC MEETINGS

The Historic District Commission recognizes that citizens who make the effort to attend a Commission meeting often feel passionately about an issue. The following guidelines are not meant to discourage individual expression; rather, they exist to facilitate the orderly conduct of business and to ensure that all citizens who wish to address the Historic District Commission are able to do so in an atmosphere of civility and respect.

- Out of respect for business being conducted during the meeting, turn off all cell phones and pagers prior to the meeting.
- Citizens have opportunities to address the Historic District Commission at the following times during a meeting:
 - Address Non-agenda items at the beginning of the meeting. If you wish to speak about a specific review, please wait until that review comes to the commission.
 - Consideration of Regular Agenda items. Citizens are permitted to speak to the Commission on project reviews after the applicant has made their presentation and prior to the Historic District Commission discussion. The Chair will call for comments from the public.

A Note on Quorum and Historic District Commission Decisions

City of Kalamazoo Code of Ordinance – Chapter 16 – Historic District Commission – section 19 states: “A majority of the members of the Commission shall constitute a quorum. A majority of the appointed members is required to take action on all matters not of an administrative nature, but a majority of a quorum may deal with administrative matters.” All applicants should be aware that the minimum of four of the commissioners must vote for a motion for a decision to be made in all actions. Applicants may choose to postpone their review to the next regularly scheduled meeting of the commission before the commission begins their deliberations if fewer than seven commissioners are present. The postponement form is available from the coordinator and must be filled out and signed before the applicant leaves the meeting.

KALAMAZOO HISTORIC DISTRICT COMMISSION

Agenda – Tuesday, March 18th, 2025

5:00 pm

241 W. South St. Kalamazoo, MI 49007

I. Call to Order: Ms. Underwood called the meeting to order at 5:02 PM

II. Roll Call & Approval of Absences:

Eric Stucky-Absent

Katie Boertman- Present

Dana Underwood – Present

Kristi Breisach- Present

James Johnson-Present

Dan Kastner- Absent

Motion made by Ms. Breisach to approve the absence of Mr. Stucky and Mr. Kastner with a second by Mr. Johnson. All commissioners approved.

Mr. Pena read the disclaimer on record.

III. Approval of Agenda:

Motion made to approve the agenda by Ms. Boertman with a 2nd by Mr. Johnson. All commissioners approve.

IV. Approval of Minutes: February 18th, 2024

Motion made by Mr. Johnson to approve the minutes with a second by Ms. Breisach; All commissioners approve.

V. Public Comment on non-agenda items: No comments and No guests

VI. OLD BUSINESS: None

NEW BUSINESS:

A) 1009 Oak

**Alteration-Removal of 1 window,
Replacement of one with Vinyl**

Year Built: 1895

**Style: Queen Anne
Historic District: South Street-
Vine Area**

Michael Braun is the current owner of the property. They have had issues with water at the property and had previously removed one window and replaced with a vinyl window. Ms. Breisach did visit the

property and the window that was removed was on the front of the property. The replacement vinyl window is partially visible from the street as well and disrupts the visual alignment of the property and the character defining features of the property. Mr. Braun did state that they had to preserve the structure and prevent mold for the tenant. Mr. Braun stated that a previous inspector had stated bubbling in the paint and that the contractor stated that the window would need to be replaced. Mr. Johnson does state that the commissions does have standards to abide by and feels the window should have been replaced with a wood window rather than vinyl. Mr. Braun did state that he attempted to do repairs to the windows previously and fixed drywall and framing around the window. Mr. Braun does state that he wasn't aware of having to follow historic standards and that this was an emergency. Ms. Boertman makes motion to approve a Certificate of Appropriateness for the work as described in the application, the proposed work complies with the Secretary of the Interior standards 2, 6, 9 and 10 with a second from Mr. Johnson. All commissions deny the application. Mr. Johnson and Ms. Underwood would like wood windows installed with the same size and same style to match what was at the property previously.

**B) 1519 Grand
Year Built: 1910**

**Alteration-Window Installation
Style: Prairie
Historic District: West Main Hill**

Mr. Tim Meengs is looking to add a window to his property. The new window is intended to match the current windows on the home. The windows would be wood windows. Ms. Breisach feels it is nice to add a window and appreciates his attention to detail. Mr. Johnson makes motion to approve a Certificate of Appropriateness for the work as described in the application, the proposed work complies with the Secretary of the Interior standards 2, 9 and 10 with a second by Ms. Breisach. All commissioners approve.

**C) 1528 W Michigan

Year Built: 1961**

**Alteration- Installation of
replacement sign, removal of
existing, non-contributing
Style: Contemporary
Historic District: West Main Hill**

Mr. Halil Dursunoglu is the current owner of the building and is looking to change the sign on the building. They have currently been using the current sign and has tried to repair it but is now looking to change it. The building is not a contributing structure in the historic district. The owner has tried to maintain it, but it is very old, and all components would need to be removed and is afraid that the sign could fall. Ms. Boertman makes a motion to approve a Certificate of Appropriateness for the work as described in the application., the proposed work complies with the Secretary of the Interior standards 9 and 10 with a second from Mr. Johnson. All commissioners approve.

VII. Coordinator's Report

- Historic District Webinar coming up.
- Administrative reviews.
- Michigan State Historic Preservation Office- Certified Local Government Program Annual Report Checklist.

VIII. Adjournment

Ms. Underwood adjourned at 5:53 PM.

Chairperson

Date

Historic Preservation Coordinator

Date

Recording secretary

Date



Historic District Commission Staff Report

City of Kalamazoo

TO: The Kalamazoo Historic District Commission
FROM: Luis Pena, Historic Preservation Coordinator
DATE: April 15, 2025
SUBJECT: 1. 430 Elm - New Construction (Construction of detached garage) PPZ25-0007

PROPOSED WORK:

From the Description of Work Supplied by the Applicant: Construction of detached 2 car garage.

EVALUATION:

Project Details

Construction of a detached garage at the rear (east) of the property.

Applicable Criteria

Secretary of the Interior's Standards for Rehabilitation

9. New additions, exterior alterations, or related new construction shall not destroy historic materials that characterize the property. The new work shall be differentiated from the old and shall be compatible with the massing, size, scale, and architectural features to protect the historic integrity of the property and its environment.

Since the proposed garage is detached from the property, construction will not destroy any historic materials that characterize the property. Additionally, the new construction will be differentiated from the historic structure since it is detached from the property. The use of some modern materials (such as aluminum) further differentiates the new construction from the historic property. The massing and design of the garage, however, are compatible with the historic property and environment.

10. New additions and adjacent or related new construction shall be undertaken in such a manner that if removed in the future, the essential form and integrity of the historic property and its environment would be unimpaired.

As noted above, since the proposed garage is detached from the historic structure, removal of the garage in the future would not impair the historic property.

Local Historic District Standards and Guidelines

New construction - Garages:

Relationship to Street/Site

- The garage must be a fully detached structure.
 - *The proposed garage is a fully detached structure*
- If the garage is to be built within the setback, approval must be gained from both the Historic District Commission and the Zoning Board of Appeals.
 - *The proposed garage conforms with zoning*
- The garage must be located behind the rear wall of the building or the side building line on a corner lot.
 - *The proposed garage is located behind the rear wall of the building.*

Roof

- Shall match the pitch of the roof of the primary resource as closely as possible.
 - *The proposed garage will have a hipped roof. The historic property has a hipped roof.*
- Preferably overhead garage doors will be single doors. Double doors will be considered. Wooden doors are preferred, but metal is acceptable. In all cases the doors must be paneled and not flat.
 - *The proposed garage door is a single metal door. it is paneled.*

Materials

Exterior siding shall be selected from the following list:

- Exterior treatment, which matches primary structure, horizontal, wood siding board and batten/false board and batten.
 - *The proposed garage will be clad in either wood or Hardie board clapboard.*

Discussion

The proposed garage will not adversely effect the existing historic structure at 430 Elm.

POTENTIAL ACTIONS:

1. The proposed work complies with the Secretary of the Interior standards 9 and 10. **Action: Motion to approve a Certificate of Appropriateness for the work as described in the application.**
2. More information is needed. **Action: Motion to postpone until the HDC meeting on 20 May 2025 and direct the applicant to provide the requested materials and information to**

the Historic Preservation Coordinator by noon on 13 May 2025.

3. Denial of the application. **Action: Motion to deny the application based on Secretary of the Interior Standards 9 and 10.**



RECEIVED
APR 03 2025
BY: Cao
✓ in SAE

Community Planning and Economic Development
Historic District Commission
245 N. Rose Street
Kalamazoo, MI 49007
Telephone: (269) 337-8804; FAX (269) 337-8513
Penal@kalamazoo.org

APPLICATION FOR PROJECT REVIEW – Historic District Commission Hearing

COMPLETE Applications for review at the Historic District Commission meeting including payment of the \$85 hearing fee must be received by NOON on the 2nd Tuesday of the month- the meeting is on the 3rd Tuesday of the month.

(PLEASE PRINT CLEARLY - See instructions on reverse side)

Property Address: 430 Elm Street; Kalamazoo MI 49007

Historic District: South/Vine Stuart West Main Hill Rose Place Haymarket

Applicant: Sharon Carlson Owner: Sharon Carlson

Mailing Add: 430 Elm Street Mailing Add: 430 Elmm Street

City State & Zip: Kalamazoo MI 49007 City, State Zip: Kalamazoo MI 49007

Phone: 269-501-2835 Phone: 269-501-2835

Email: carlson.sharon@sbcglobal.net Email: carlson.sharon@sbcglobal.net

Contractor Pennings

Work to be done by owner

Proposed Work: Use additional sheets to describe work if necessary

Construction of detached 2 car garage. See additional notes, plans.

(see AK) This property has at least one working smoke detector for each dwelling unit.
(Owner or applicant's initials) (Required) * see back

Applicant's Signature: [Signature] Date: 4-4-25

Owner's Signature: [Signature] Date: _____
(if different)

APPLICATION CHECKLIST:
Include all these items are in your submission. Incomplete applications will be held until the next review hearing.

- Drawings 11x17 or smaller with dimensions
- Materials list
- Site plan including north arrow
- Other:
- \$85 for HDC hearing & review fee – must be paid in advance to be placed on agenda – include WITH application – Check payable to: City of Kalamazoo

-For Historic Preservation Coordinator's Use Only-

Case Number: PPZ- 25-0007 Date Received*: 03 APRIL 2025
Zoning RD-19 Year built 1860 Complete application yes
Owned since _____

COMMISSION Meeting Date 15 APRIL 2025 Hearing fee paid \$85 _____
Check # _____
COMMENTS _____

Approve in Concept Date _____ Letter mailed _____

FINAL ACTION

Approve Site Visit Approve w/Conditions Deny Postpone Withdrawn

ACTION DATE _____
Certificate of Appropriateness Issued _____
Notice of Denial with appeals information _____
Notice to Proceed _____ Comments _____

Revised November 22, 2019

Construction Details, Garage Project 430 Elm Street, Kalamazoo, MI 49007 Sharon Carlson

Construction of new two car detached garage on lot behind house at 430 Elm Street. The garage is going to be located on the site of a previous house (729 W. Willard was the address for this house). The house burned in February 1994. I bought the lot and house at the same time in 1996 and have since had the two parcels combined into a single parcel for 430 Elm Street.

The garage will be constructed of wood and Hardie board. The garage will have one window and a service door. The service door will be on the west side of the garage. The garage door will be a paneled metal overhead door to reflect surrounding architectural details.

This project previously received conceptual approval in 2009 when the back porch was designed and constructed.

Materials Listing Garage Project, 430 Elm Street; Kalamazoo MI 49007 Sharon Carlson

Siding will be lumber or Hardie board to look like standard wood frame construction and match the house.

Garage door will be selected to be compatible. The porch that was added to the rear of the house was designed to fit in with the two houses constructed on Willard Street, ca. 2013.

Shingles to match the shingles on the house, black asphalt

REVISION	DATE	BY
1	03/07/25	ST
2	03/07/25	ST
3	03/07/25	ST
4	03/07/25	ST
5	03/07/25	ST
6	03/07/25	ST
7	03/07/25	ST
8	03/07/25	ST
9	03/07/25	ST
10	03/07/25	ST

Sharon Carlson & Tom Dietz
Kalamazoo, MI 49007
430 Elm Street

DATE: March 27, 2025
DRAWN BY: ST
CHECKED BY: ST
SCALE: 1/4" = 1'-0"

PAGE 72
ELEVATIONS,
FLOOR PLANS,
& SECTIONS

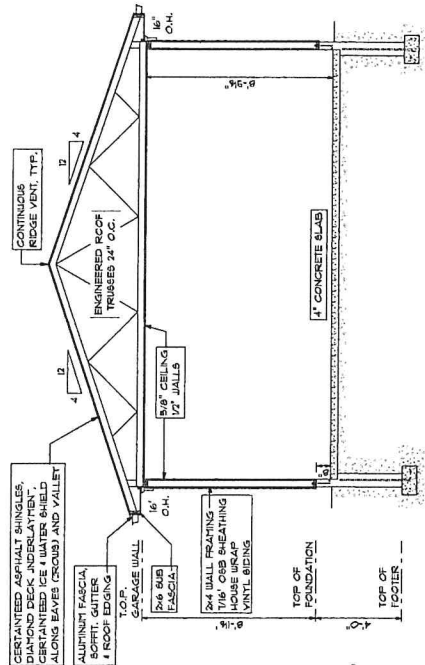

PROPOSED SECTION
SCALE: 3/8" = 1'-0"

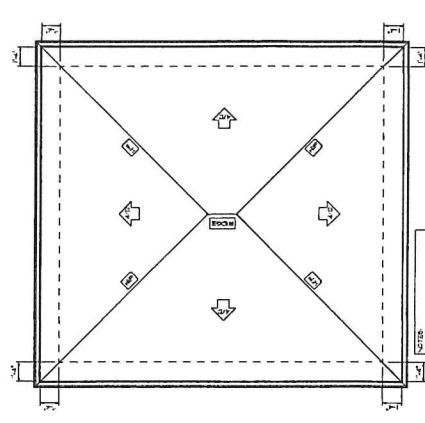
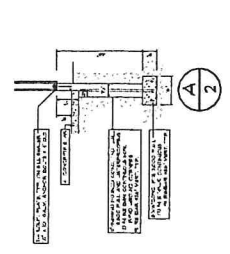

PROPOSED ROOF
SCALE: 1/4" = 1'-0"

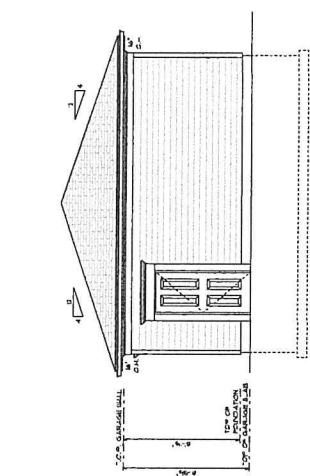

PROPOSED SOUTH ELEVATION
SCALE: 1/4" = 1'-0"

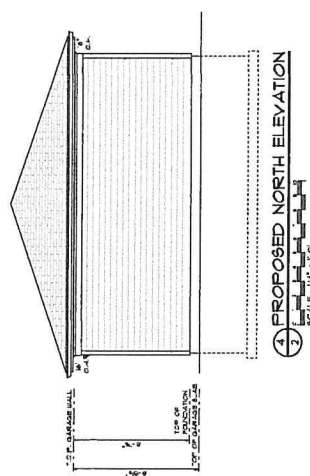

PROPOSED NORTH ELEVATION
SCALE: 1/4" = 1'-0"

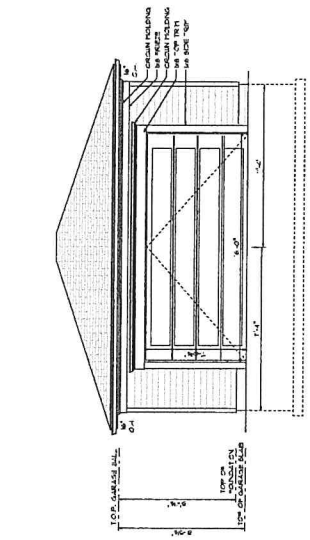

PROPOSED WEST ELEVATION
SCALE: 1/4" = 1'-0"

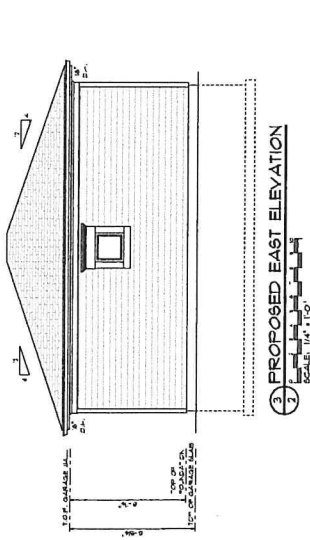

PROPOSED EAST ELEVATION
SCALE: 1/4" = 1'-0"

NO.	DESCRIPTION	QUANTITY	UNIT
1	2x6 GARAGE WALL	1	LINEAR FOOT
2	2x4 WALL FRAMING	1	SQUARE FOOT
3	1/2\"/>		

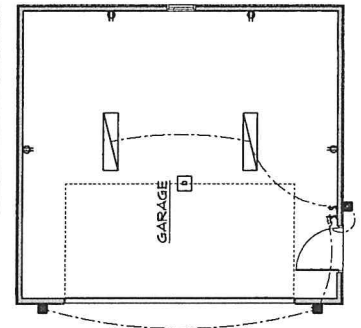

ELECTRICAL MAIN FLOOR
SCALE: 1/4" = 1'-0"

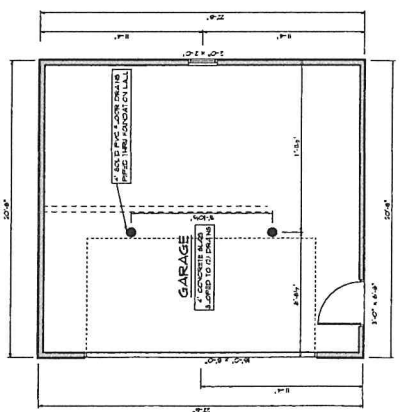

PROPOSED MAIN FLOOR
SCALE: 1/4" = 1'-0"

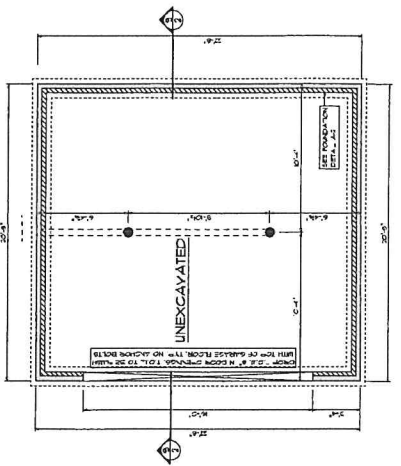

PROPOSED FOUNDATION
SCALE: 1/4" = 1'-0"



Historic District Commission Staff Report

City of Kalamazoo

TO: The Kalamazoo Historic District Commission

FROM: Luis Pena, Historic Preservation Coordinator

DATE: April 15, 2025

SUBJECT: 2. 107, 115 and 119 W Vine - Demolition (Demolition of 5 buildings) PPZ25

PROPOSED WORK:

From the Description of Work Supplied by the Applicant: The B on Burdick presents a once-in-a-generation opportunity to transform a single, blighted site into a vibrant community hub that delivers what residents need most: early education, quality housing, and economic opportunity. We respectfully request the Historic Commission's approval for the proposed demolitions so that this critical investment in Kalamazoo's future can move forward.

EVALUATION:

Project Details

Demolition of 5 structures across 3 parcels on W Vine St.

Applicable Criteria

Work within an historic district shall be permitted through the issuance of a notice to proceed by the Historic District Commission if any of the following conditions prevail and if the proposed work can be demonstrated by a finding of the Historic District Commission to be necessary to substantially improve or correct any of the following conditions:

(1)

The resource constitutes a hazard to the safety of the public or to the occupants.

N/A

(2)

The resource is a deterrent to a major improvement program which will be of substantial benefit to the community and the applicant proposing the work has obtained all necessary planning and zoning approvals, financing and environmental clearances.

Per the application, the 5 structures in question, across 3 parcels, are deterrents to a development at the south-west corner of W Vine and S Burdick. The community benefits as listed in the application include the construction of an early learning center for 40-50 children

and 80 housing units in the Vine neighborhood. Additionally, the application points to alignment with the Vine Neighborhood Plan, specifically the promotion of increasing housing options through mixed-use development in the neighborhood (Vine Neighborhood Plan 2019, 11). The plan also cites areas the stimulation of local business growth and economic vitality through the promotion of walkable mixed-used developments along key corridors, such as Burdick (Vine Neighborhood Plan 2019, 27).

(3)

Retention of the resource would cause undue financial hardship to the owner when a governmental action, an act of God, or other events beyond the owner's control created the hardship, and all feasible alternatives to eliminate the financial hardship, which may include offering the resource for sale at its fair market value or moving the resource to a vacant site within the historic district, have been attempted and exhausted by the owner.

N/A

(4)

Retaining the resource is not in the interest of the majority of the community.
There has been no indication that the retention of the properties in question is in the interest of the majority of the community.

Discussion

According to the application, the demolition of the properties in question will allow for the construction of a mixed-use building which aligns with goals listed in the Vine Neighborhood's plan. This alignment constitutes a benefit to the Vine Neighborhood, and thus aligns with criteria 2. While it is unknown if all requisite other permissions have been obtained, the project instill in early stages.

The community has not indicated interest in the retention of the resources in question.

POTENTIAL ACTIONS:

1. The proposed work complies with the Notice to Proceed Criteria 2 and 4. **Action: Motion to approve a Notice to Proceed for the work as described in the application.**

2. More information is needed. **Action: Motion to postpone until the HDC meeting on 20 May 2025 and direct the applicant to provide the requested materials and information to the Historic Preservation Coordinator by noon on 13 May 2025.**

3. Denial of the application. **Action: Motion to deny the application based on Notice to Proceed Criteria 2 and 4.**



Community Planning and Economic Development
 Historic District Commission
 245 N. Rose Street
 Kalamazoo, MI 49007
 Telephone: (269) 337-8804; FAX (269) 337-8513
Penal@kalamazoo.org

APPLICATION FOR PROJECT REVIEW – Historic District Commission Hearing

COMPLETE Applications for review at the Historic District Commission meeting including payment of the \$85 hearing fee must be received by NOON on the 2nd Tuesday of the month- the meeting is on the 3rd Tuesday of the month.

(PLEASE PRINT CLEARLY - See instructions on reverse side)

Property Address: _____

Historic District: South/Vine Stuart West Main Hill Rose Place Haymarket

Applicant: _____ Owner: _____

Mailing Add: _____ Mailing Add: _____

City State & Zip: _____ City, State Zip: _____

Phone: _____ Phone: _____

Email: _____@_____ Email: _____@_____

Contractor _____

Work to be done by owner

Proposed Work: Use additional sheets to describe work if necessary

APPLICATION CHECKLIST:
 Include all these items are in your submission. Incomplete applications will be held until the next review hearing.

- Drawings 11x17 or smaller with dimensions
- Materials list
- Site plan including north arrow
- Other:
- \$85 for HDC hearing & review fee – must be paid in advance to be placed on agenda – include WITH application – Check payable to: City of Kalamazoo

(_____) This property has at least one working smoke detector for each dwelling unit.
 (Owner or applicant's initials) (Required) * see back

Applicant's Signature: Jamauri Bogan Date: _____

Owner's Signature: bronsonhg-BHGCA01-CA Date: _____
 (if different)

-For Historic Preservation Coordinator's Use Only-

Case Number: PPZ- 25-0008 Date Received*: 04/07/2025

Zoning CC, RM-36 Year built Various, see Report Complete application Yes

Owned since Various, see report

COMMISSION

Meeting Date 04/15/2025

Hearing fee paid \$85 _____

Check # _____

COMMENTS _____

Approve in Concept Date _____ Letter mailed _____

FINAL ACTION

Approve Site Visit Approve w/Conditions Deny Postpone Withdrawn

ACTION DATE _____

Certificate of Appropriateness Issued _____

Notice of Denial with appeals information _____

Notice to Proceed _____ Comments _____

Revised November 22, 2019

APPLICATION FOR PROJECT REVIEW – Historic District Commission Hearing

COMPLETE Applications for review at the Historic District Commission meeting including payment of the \$85 hearing fee must be received by NOON on the 2nd Tuesday of the month- the meeting is on the 3rd Tuesday of the month. Incomplete applications will be postponed until the next meeting.

Filling out the application – instructions and tips – PLEASE PRINT.

Property address: street address of the property where the work will be done

Historic district: Stuart, South Street/Vine Area, Haymarket, West Main Hill or Rose Place

Applicant: Owner or the owner's contractor.

Owner: Legal owner of property

Mailing Address: Applicant's address

Mailing Address: Owner's address

City, State & Zip:

City, State & Zip:

Phone: Specify home or work

Phone: Specify home or work

Email

Email

Name of the contractor if this project requires a building permit Or indicate work done by owner

Proposed Work: What work do you plan to do? Please be as specific as possible including a complete description of the part of the structure where work will be done.

Example #1: Rather than "Build new garage"

Say "Build new two car garage near northeast corner of lot, wooden frame with clapboard siding, paneled metal overhead door, service door on the north side and one window at the rear. "

Example #2: Instead of "New front door"

Say "Install a new wooden front door to fit original opening in width and height, to replace the existing metal paneled door. See drawing/photo for appearance" Specify the measurements of the width and height of the original opening. Include a storm door if that is part of the project

For more complex projects, please include as many **continuation or illustration sheets** as you need to present a clear picture to the commission of your proposed work.

- Drawings – black or blue black ink on white paper. Electronic submissions are encouraged. Drawings should include dimensions of the existing part of the building and the proposed work.
- You need submit only one set of drawings; city staff will make the necessary copies.
- Use the checklist to be sure you have supplied all the important information.
- For new construction) exterior stairs, new garage, reconstructing a porch, etc) a site plan WITH a north arrow is required.

*(_____) This property has at least one working smoke detector for each dwelling unit. Please initial to verify at least one working smoke detector in each dwelling unit. This is REQUIRED by state law or the application will be considered incomplete.

PHOTOS: The historic preservation coordinator is responsible for taking photographs of the proposed work and the structure. If you wish to take additional photos, one set is usually adequate for the commissioners to examine. You may also bring photos on a USB drive to share with the commission.

Emergency repairs: If damage occurs to a structure in a historic district, which requires emergency repairs, steps may be taken to secure the structure without the approval of the commission or the coordinator. Cover damaged windows or holes in a roof with tarps or wood to prevent further damage. Support dangling or loose elements or remove and store them. Notify the Coordinator of the damage to the structure on the first weekday available after the damage occurs and the coordinator will visit the structure as well as arranging a site visit by commission members to approve repairs if necessary. **THIS WILL BE DONE AS QUICKLY AS POSSIBLE IN ORDER TO FACILITATE REPAIRS OF THE STRUCTURE IN A TIMELY MANNER.**

If you have questions about completing this application for project review, please call the Historic Preservation Coordinator at: (269) 337-8804 or by email at Penal@kalamazocity.org

Letter of Acknowledgment

April 7, 2025

To whom it may concern.

This is to acknowledge an agreement between Kalamazoo Forward Ventures LLC and Shinda Sons LLC that Shinda Sons LLC is aware of the demolition of the following properties

107 W. Vine St Kalamazoo, MI 49001.

Thank You!

Shinda Sons LLC

dotloop verified
04/07/25 10:58 AM EDT
8WIK-YOF8-SWKW-PJZH

Shind Sons LLC.



BOGAN
DEVELOPMENTS

Historic District Commission

More Than Just Buildings



At Bogán Developments, ELITE is not just a word—it is our mindset, our commitment, and the measure of everything we do to elevate lives and communities.

TYPE OR REMOVE ADDITIONAL TEXT IN FOOTER

WWW.BOGANDEVELOPMENTS.COM | February 1, 2025

Executive Summary

The B on Burdick: Advancing Community Development through Workforce Housing and Neighborhood-Based Amenities

Overview:

The B on Burdick is a transformative mixed-use development that will revitalize a blighted section of the Vine neighborhood by replacing an obsolete liquor store and deteriorating infrastructure with high-quality workforce housing, an early learning center, and resident-focused amenities. This initiative aligns with the Historic Commission's Guideline (b), as the existing structures at 107, 115, and 119 W Vine currently stand as barriers to a vital community revitalization effort.

Key Project Benefits:

- **Removal of a Problematic Liquor Store:** This will reduce crime, improve neighborhood safety, and enhance the overall character of the Vine community.
- **Early Learning Center for 40–50 Children:** In a neighborhood where only 65% of children graduate high school, this center will provide crucial early education, helping to shift long-term academic and life outcomes.
- **Workforce Housing for Local Residents:** The project will deliver 80 high-quality, attainable housing units designed for Kalamazoo residents, including employees of Bronson Healthcare and other local institutions.
- **Alignment with the Vine Neighborhood Plan:** The B on Burdick reinforces the City's vision for mixed-use, mixed-income, and pedestrian-friendly development—strengthening the social and economic fabric of the neighborhood.

Project Components:

- **Residential Units:** 80 thoughtfully designed studio, one-bedroom, and two-bedroom apartments for a range of income levels.
- **Commercial Space:** 15,000 sq. ft. dedicated to an early learning center and on-site amenities supporting families and neighborhood residents.
- **Economic Development:** Supports downtown Kalamazoo's workforce—especially those facing increasing housing costs near the city core

Bronson Healthcare's Commitment to Housing & Community Investment:

As the region's largest employer with over 9,000 employees, Bronson Healthcare has a long-standing commitment to health equity and addressing the social determinants of health. Each year, Bronson contributes more than \$147 million in uncompensated benefits to the region. Expanding its Healthy Living Campus to include workforce housing is a natural and necessary step toward building a healthier, more resilient community.

The Bronson Healthy Living Campus: A Master-Planned Community Anchor

Launched in 2016, the campus has transformed a former industrial area into a vibrant center of health and opportunity, including:

- **KVCC Culinary and Allied Health Building** – providing health-focused workforce training
- **KVCC Food Innovation Center** – promoting sustainable food systems
- **KCMHSAS Integrated Health Services Building** – offering mental health and pharmacy services
- **Urban Agriculture Initiatives** – increasing access to fresh food and supporting neighborhood renewal

The addition of The B on Burdick will further deepen Bronson's investment in Block M and the city of Kalamazoo.

Key Development Partners:

- **Bronson Healthcare Group** – Southwest Michigan’s largest employer and community anchor
- **Kalamazoo Forward Ventures (KZfV)** – a \$50M African American-led investment fund focused on inclusive, equitable development
- **Bogan Developments** – a minority-owned real estate firm dedicated to elevating living standards through affordable and workforce housing
- **AVB** – a premier construction management firm with over \$1 billion in projects delivered across Southwest Michigan
- **TowerPinkster** – an award-winning, Kalamazoo-based design firm specializing in community-centered architecture

Closing Statement:

The B on Burdick presents a once-in-a-generation opportunity to transform a single, blighted site into a vibrant community hub that delivers what residents need most: early education, quality housing, and economic opportunity. We respectfully request the Historic Commission’s approval for the proposed demolitions so that this critical investment in Kalamazoo’s future can move forward.

Exhibit A:

Exhibit A highlights the enduring legacy of ELITE apartments that have served the Vine Neighborhood for more than a century. This project stands proudly in that tradition—poised to deliver the next great building that reflects the neighborhood’s aspirations, values, and historical depth.

PROPOSED BUILDINGS TO BE REMOVED

- 1. 119 W VINE ST - IN HDC
NON CONTRIBUTING
- 2. 115 W VINE ST -IN HDC
- 3. 107 W VINE ST - IN HDC
- 4. 107 W VINE ST - IN HDC
- 5. 107 W VINE ST - IN HDC

- 6. 802 S BURDICK ST - NON HDC
- 7. 814 S BURDICK ST - NON HDC
- 8. 824 S BURDICK ST - NON HDC

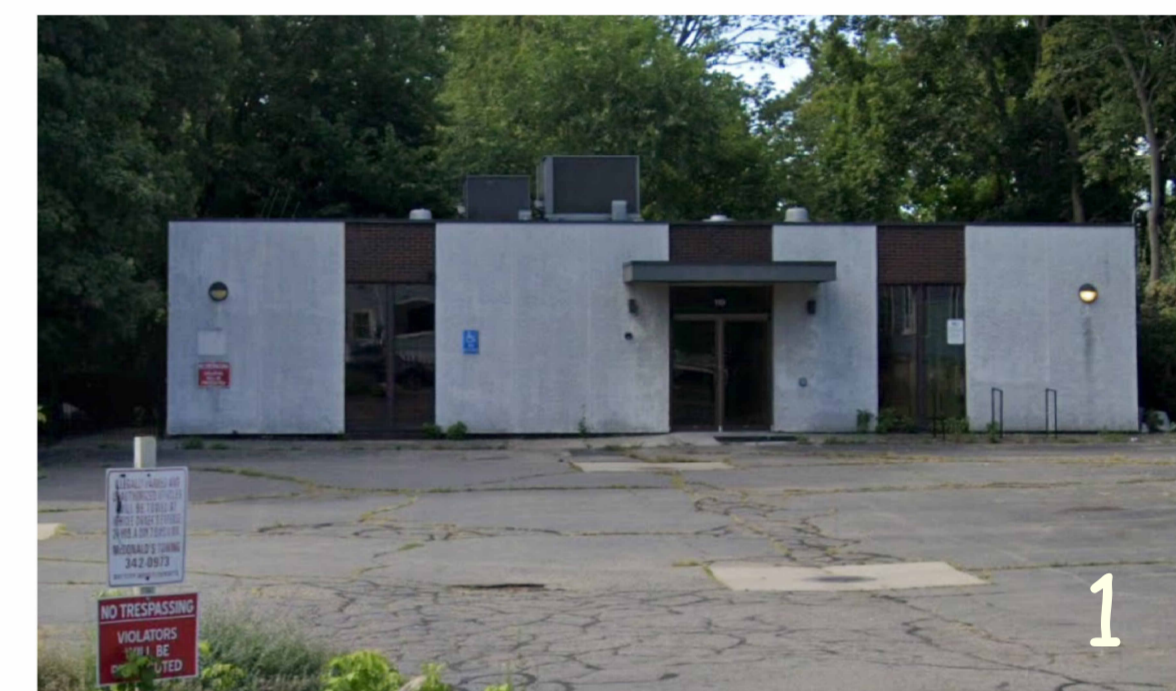
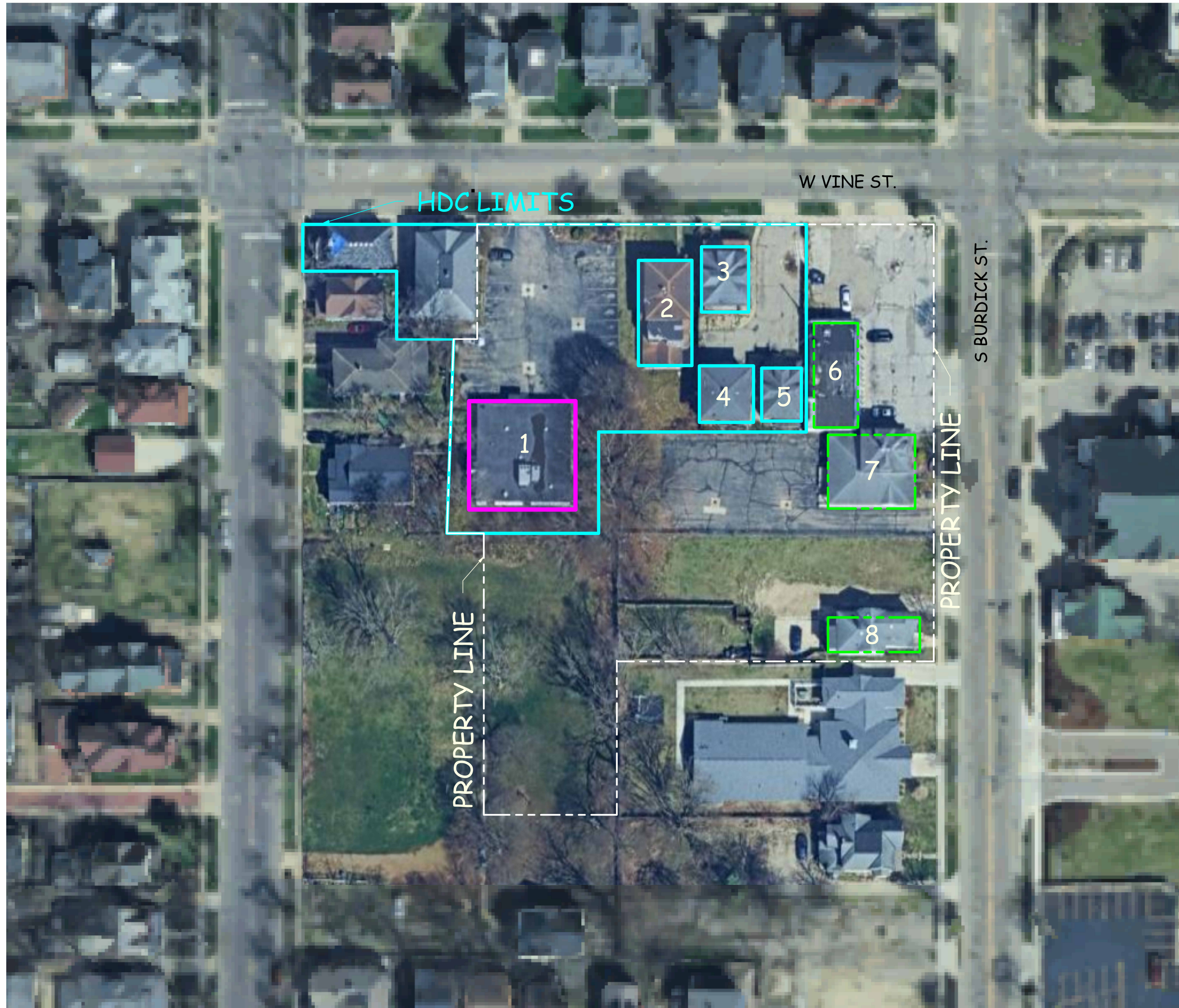

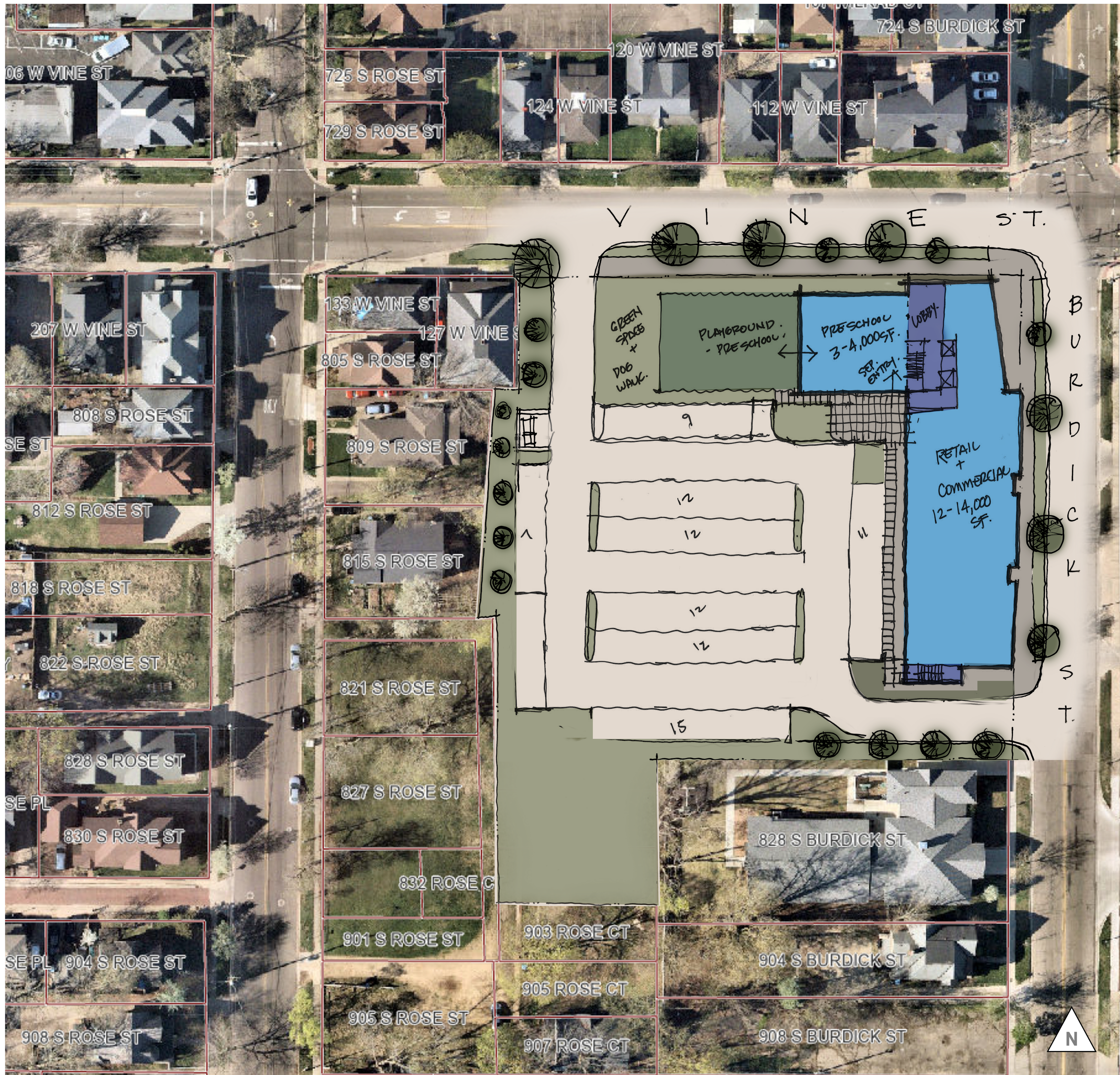

FIRST FLOOR ALLOCATIONS

- RETAIL + COMMERCIAL: 18,000 SF
 - 3-4,000 SF
 - 12-14,000 SF
- SHARED/ CIRCULATION
- PARKING: 90 SPACES
INCL ADA + LOADING

BUILDING TOTALS:

- RETAIL + COMMERCIAL: 15-18,000 SF
- RESIDENTIAL: 80 UNITS
- PARKING: 90 SPACES
INCL ADA + 1 LOADING

FIRST FLOOR + SITE CONCEPT
SCALE: 1" = 30'-0"

Vine
Neighborhood
Historic
Apartment
Buildings

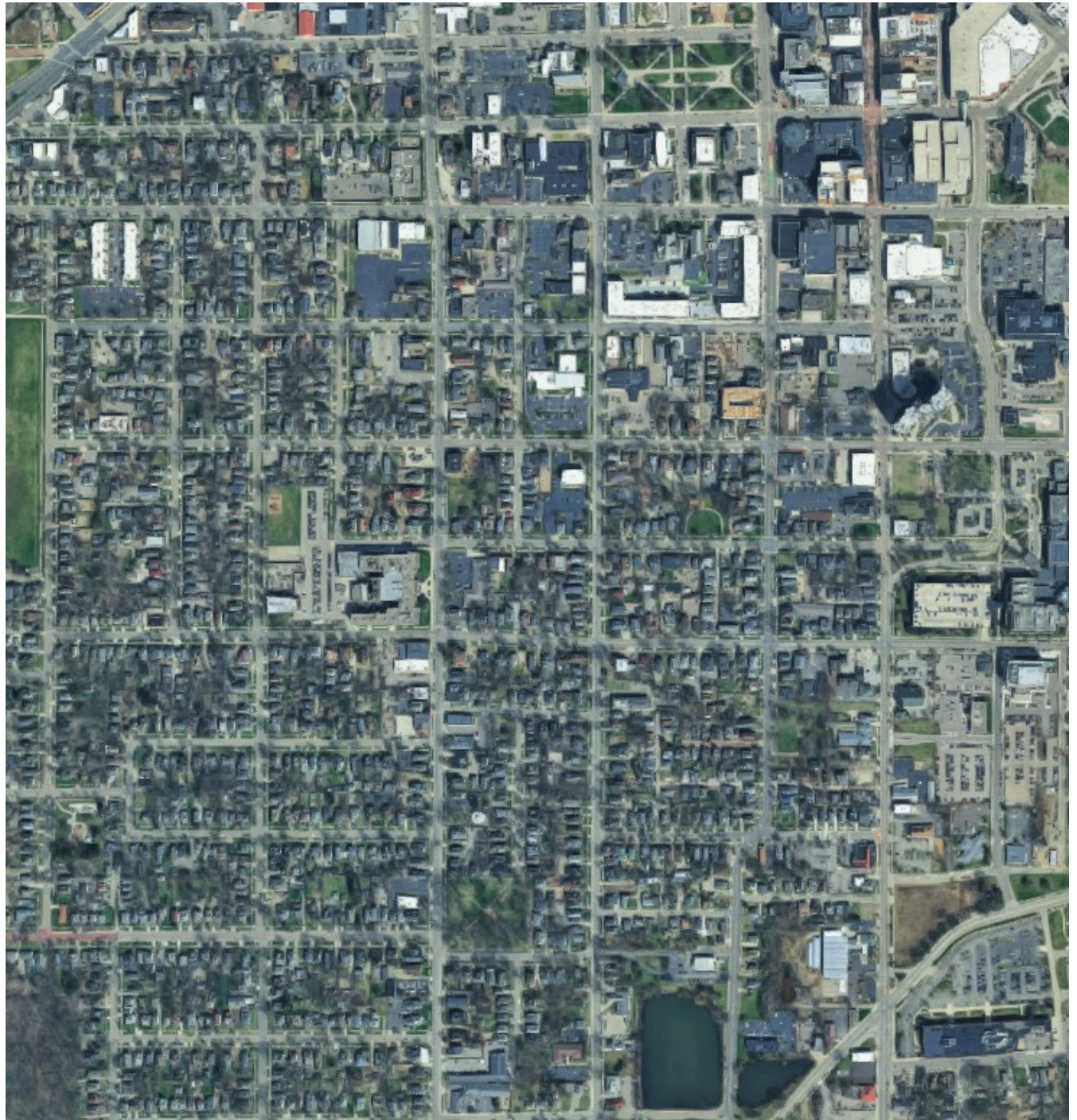

W. Walnut St.



W. Dutton St.



W. Cedar St.



W. South St.



W. South St.



Academy St.



W. South St.



S. Rose St.



S. Park St.





Historic District Commission Staff Report

City of Kalamazoo

TO: The Kalamazoo Historic District Commission

FROM: Luis Pena, Historic Preservation Coordinator

DATE: April 15, 2025

SUBJECT: 3. 807 W Vine - Alteration (Replacement of windows) PPZ24-0035 Postponed Review

PROPOSED WORK:

From the Description of Work Supplied by the Applicant: Replace the windows with vinyl double hung windows.

EVALUATION:

Project Details

Replacing all windows with vinyl, double hung windows. It is unclear whether or not the new windows will fit the existing openings, or if the new windows will replicate the muntin pattern of the existing windows.

Applicable Criteria

Secretary of the Interior's Standards for Rehabilitation

2. The historic character of a property shall be retained and preserved. The removal of historic materials or alteration of features and spaces that characterize a property shall be avoided.
The wood windows are a character defining feature of the property, especially the windows with multiple lights in the upper sash (such as on the primary facade of the property, and some of the windows on secondary facades). The multiple lights of the upper sashes are also characteristic of the Tudor Revival Style.

5. Distinctive features, finishes, and construction techniques or examples of craftsmanship that characterize a historic property shall be preserved.
The existing windows in the property, especially those with divided lites, are examples of craftsmanship that characterizes the historic property. These windows should be preserved.

6. Deteriorated historic features shall be repaired rather than replaced. Where the severity of

deterioration requires replacement of a distinctive feature, the new feature shall match the old in design, color, texture, and other visual qualities and, where possible, materials. Replacement of missing features shall be substantiated by documentary, physical, or pictorial evidence.

The application states that some repairs were attempted on the property that proved unsuccessful. The level of deterioration is unclear in the pictures, which show the meeting rails of 2 windows and the parting bead of another. The written portion of the application states that the windows have been painted shut, and that there is severe sill damage.

The application does not include what the replacement windows will look like, so it is difficult to determine if the proposed replacements will reasonably replicate the existing windows in appearance.

9. New additions, exterior alterations, or related new construction shall not destroy historic materials that characterize the property. The new work shall be differentiated from the old and shall be compatible with the massing, size, scale, and architectural features to protect the historic integrity of the property and its environment.

The removal of the existing windows would remove the existing wooden windows in the property, which are character defining features. The new work would be differentiated from the old through the use of modern materials. Since there were no depictions of the proposed windows submitted, it is difficult to know if they will be compatible with the size and architectural features of the existing structure.

10. New additions and adjacent or related new construction shall be undertaken in such a manner that if removed in the future, the essential form and integrity of the historic property and its environment would be unimpaired.

If the existing openings of the windows were retained, the windows could be removed without impairing the integrity and essential form of the historic property.

Local Historic District Standards and Guidelines

Guidelines for replacement:

If replacing the entire window becomes necessary, the following conditions shall be applied:

- The dimension of the original window must be retained.
 - *It is unclear from the application whether or not the dimensions of the existing windows will be retained.*
- Muntins, sash, frames, exterior casing and brick molds must be of material and dimensions to match other windows in the house.
 - *It is unclear from the application whether or not the new sashes would reasonably replicate the existing windows.*
- Aluminum and vinyl clad windows do not meet the above requirements. Vinyl plastic windows are not acceptable because they are made of non-historic materials and do not comply with the Secretary of the Interior's Standards for Rehabilitation.
 - *While the proposed vinyl windows do not align with the historic material, it is unclear if they will reasonably replicate the windows in appearance.*

Discussion

From the application, it is difficult to determine the extent of the damage to the existing wood windows. Additionally, it is difficult to understand if all of the windows are equally deteriorated,

or if there are a few windows that are in more advanced stages of deterioration than others. Finally, without being able to assess the style of the proposed new windows, it is not possible to determine how closely replacements would align with the historic character of the property.

POTENTIAL ACTIONS:

1. The proposed work complies with the Secretary of the Interior standards 2, 5, 6, 9 and 10. **Action: Motion to approve a Certificate of Appropriateness for the work as described in the application.**
2. More information is needed. **Action: Motion to postpone until the HDC meeting on 20 May 2025 and direct the applicant to provide the requested materials and information to the Historic Preservation Coordinator by noon on 13 May 2025. Because this is a postponed review of application, further postponement will need to be agreed upon in writing by both the applicant and either the preservation coordinator or the HDC.**
3. Denial of the application. **Action: Motion to deny the application based on Secretary of the Interior Standards 2, 5, 6, 9 and 10.**

✓ 1017 - \$8500 in safe



RECEIVED
OCT 08 2024
BY: Cas

Community Planning and Economic Development
Historic District Commission
245 N. Rose Street
Kalamazoo, MI 49007
Telephone: (269) 337-8804; FAX (269) 337-8513
Penal@kalamazoo.org

APPLICATION FOR PROJECT REVIEW – Historic District Commission Hearing

COMPLETE Applications for review at the Historic District Commission meeting including payment of the \$85 hearing fee must be received by NOON on the 2nd Tuesday of the month- the meeting is on the 3rd Tuesday of the month.

(PLEASE PRINT CLEARLY - See instructions on reverse side)

Property Address: 807 W Vine street
Historic District: South/Vine Stuart West Main Hill Rose Place Haymarket
Applicant: Viccarly Castellanos Owner: Viccarly Castellanos
Mailing Add: 3062 Kalamazoo ave Mailing Add: ''
City State & Zip: Portage City, State Zip: ''
Phone: 414-248-3686 Phone: ''
Email: Viccarly@gmail.com Email: @''

Contractor

Work to be done by owner

Proposed Work: Use additional sheets to describe work if necessary

Vendor/contractor: Practical Glass

(VC) This property has at least one working smoke detector for each dwelling unit.
(Owner or applicant's initials) (Required) * see back

Applicant's Signature: Viccarly Castellanos Date: 10/8/2024
Owner's Signature: [Signature] Date: 10/8/2024
(if different)

APPLICATION CHECKLIST:
Include all these items are in your submission. Incomplete applications will be held until the next review hearing.

- Drawings 11x17 or smaller with dimensions
- Materials list
- Site plan including north arrow
- Other:
- \$85 for HDC hearing & review fee – must be paid in advance to be placed on agenda – include WITH application – Check payable to: City of Kalamazoo

-For Historic Preservation Coordinator's Use Only-

Case Number: PPZ- 24-0035 Date Received*: 10/08/2024
Zoning RM-15 Year built 1915 Complete application _____
Owned since 06/27/2022

COMMISSION

Meeting Date 10/15/2024

Hearing fee paid \$ 85 _____

Check # _____

COMMENTS

Approve in Concept Date _____ Letter mailed _____

FINAL ACTION

Approve Site Visit Approve w/Conditions Deny Postpone Withdrawn

ACTION DATE

Certificate of Appropriateness Issued _____

Notice of Denial with appeals information _____

Notice to Proceed _____ Comments _____

Viccarly Castellanos
3062 Kalarama Ave. Portage MI 49024
414-248-3686
Viccarly@gmail.com
October 8/2024

Historic District Commission
Kalamazoo Historic Preservation Coordinator
245 N. Rose Street, Kalamazoo, MI 49007

Dear Members of the Historic District Commission, I am writing to request your consideration in allowing us to replace the windows of our property located at 807 W Vine Street, which lies within the Kalamazoo Historic District. My husband and I purchased this home in 2022 with full awareness of its historical significance and the beauty it contributes to the neighborhood. However, the windows, which are over 110 years old, have suffered extensive neglect and are in a state that presents major challenges.

Upon purchasing the property, one of our immediate concerns was the condition of the windows, as we could not even get many of them to open. To address this, we spent \$1,400 in repairs, but it quickly became clear that this was only a temporary solution. The windows remain highly inefficient and drafty, significantly impacting energy usage. During the first year we rented the property, we included gas and electric as part of the rent. However, with winter heating costs running as high as \$700 per month due to the windows' inefficiency, it became unsustainable. The following year, we excluded utilities from the rent, but our tenants eventually left due to the high costs associated with the property's energy inefficiency.

We deeply appreciate the architectural integrity of homes in Kalamazoo's historic district. In fact, we are fortunate enough to own two properties in the district. Our other property, though more than 100 years old, is in better shape as its windows were never painted or sealed shut. Unfortunately, the windows at 807 W Vine have been painted shut multiple times over the decades, and the wood has rotted to the point of no return. Water damage continues to worsen, and despite our best efforts, the windows are beyond repair. The sills have deteriorated to such an extent that no amount of restoration will allow them to properly seal or operate.

As responsible homeowners, we have been making significant repairs to the property since our previous tenants left in August, in the hopes of getting the house ready for rent by November. However, we are quickly running out of options regarding the windows. While we understand and respect the district's guidelines on preserving the historic nature of homes, it is simply not feasible for us to replace these windows with new wood ones, which would cost upwards of \$30,000. Given that this is a \$140,000 property, we believe that high-quality, wood-appearance vinyl windows are a more reasonable and equitable solution.

We recognize that other properties along Vine Street have installed vinyl windows, and we hope you will consider our request to do the same. It is our goal to preserve and improve the home while ensuring it remains financially sustainable for both us and any future tenants. Thank you for considering our plea to save 807 W Vine Street. We would greatly appreciate any support and guidance you can provide to help us move forward.

Sincerely,

Viccarly Castellanos

Francisco Castellanos

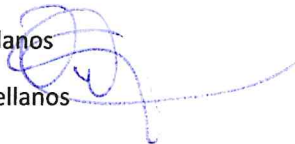

All windows on 807 W Vine Street: These are vinyl double hung windows with double pain insulated glass and full screens be white depending on the brand we can get.

Upstairs North side of house
40 x 57 3/4 (2)

Upstairs West side of house
40 x 57 3/4
32 x 57 3/4 (2)

Upstairs South side of house
32 x 57 3/4 (2)

Upstairs East side of house
32 x 57 3/4 (2)
28 x 56 3/4 (stairs)

Downstairs North side of house
24 x 65 3/4 (2)
40 1/4 x 65 3/4

Downstairs West side of house
33 x 65 3/4
59 1/2 x 66
31 1/2 x 65 3/4

Downstairs South side of house
31 1/2 x 65 3/4

Downstairs East side of house
32 x 53 (2)

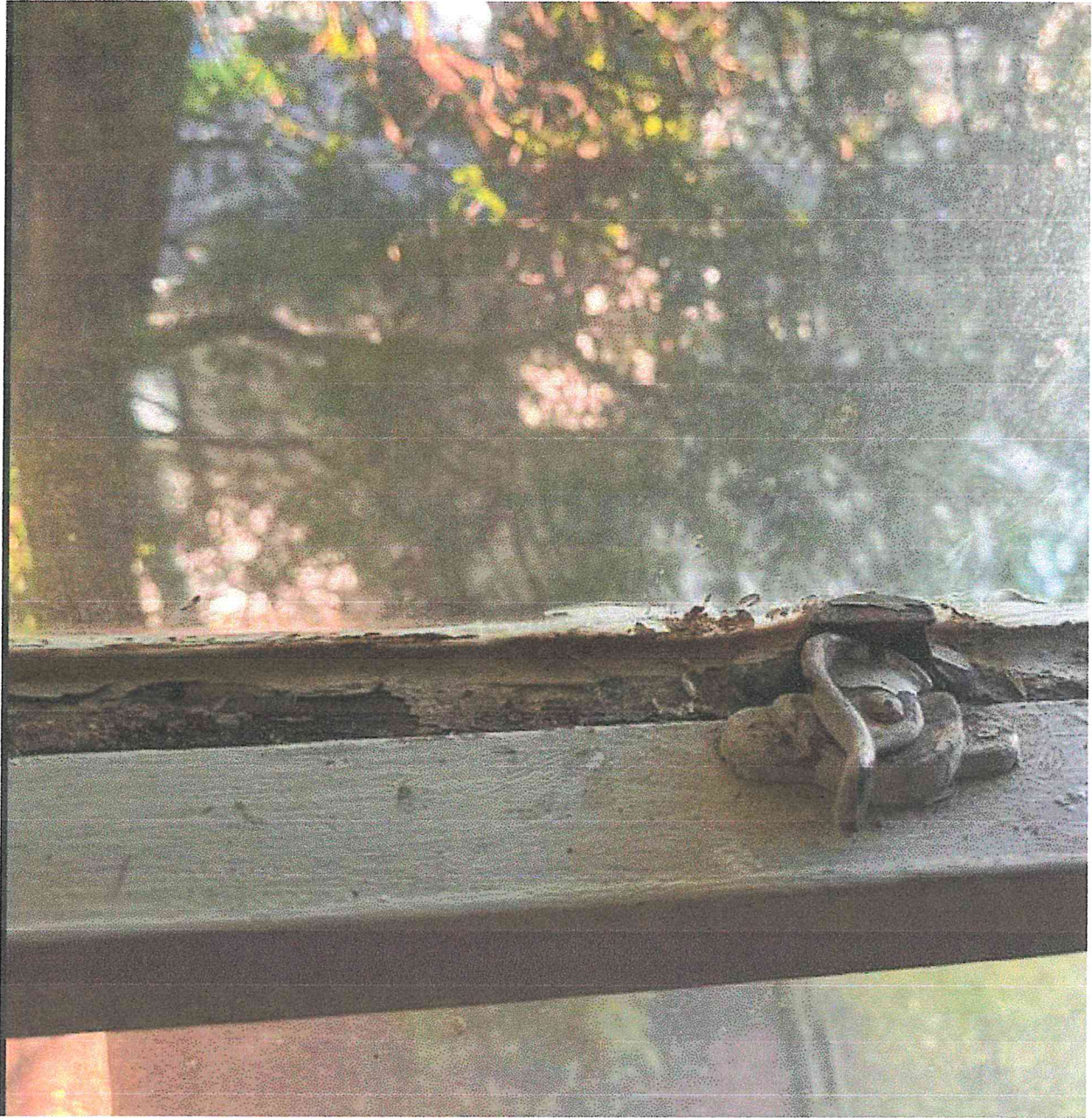



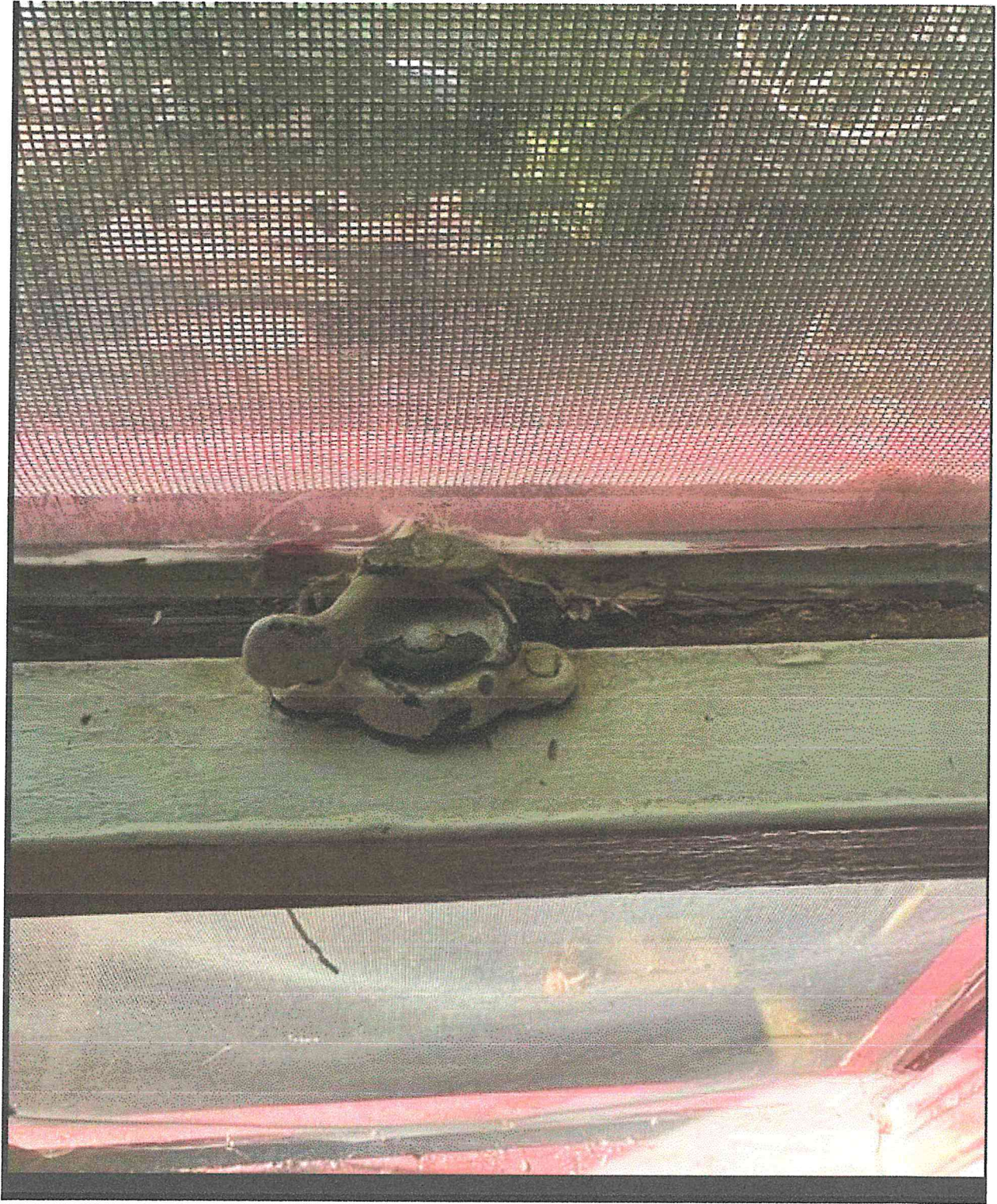



807

807





807



Historic District Commission Staff Report

City of Kalamazoo

TO: The Kalamazoo Historic District Commission
FROM: Luis Pena, Historic Preservation Coordinator
DATE: 15 April 2025
SUBJECT: Historic Preservation Coordinator's Report

Historic District Reviews

Review Type	Cost	Number of Reviews	Totals
Administrative	\$35	11	\$385
Hearing	\$85	6	\$410
		17	\$895

Administrative Reviews:

812 S Park St - Roof
802 S Westnedge - Sign reface
522 Village - Porch repair

Community Planning and Economic Development Department | 245 N. Rose Street, Ste 100, Kalamazoo, MI 49007
Voice: (269) 337-8744 | Fax: (269) 337-8513 | www.kalamazoocity.org