

Agenda

Historic District Commission

City of Kalamazoo



Tuesday, June 16, 2026

5:00 PM

City Commission Chambers at City Hall – 241 West South Street

A. CALL TO ORDER/ROLL CALL

1. Call to Order/Roll Call

B. ADOPTION OF FORMAL AGENDA

C. APPROVAL OF MINUTES

1. Approval of the minutes from the Historic District Commission meeting on

D. PUBLIC COMMENTS

E. APPLICATION REVIEWS

1. 808 W South St - Alteration(Replacement of two third floor windows) PHDC26-006
Year Built: 1915
Style: Queen Anne
Historic District: South Street - Vine Area
2. 613 Douglas - Alteration (installation of wheelchair ramps on the front and rear of the property) PHDC26-007 *Retroactive Review*
Year Built: 1957 (According to BSA)
Style: Queen Anne
Historic District: Stuart

F. COORDINATOR'S REPORT

1. Coordinator's Report

G. ADJOURNMENT

DISCLAIMER

Chapter 16, Section 22 of the City of Kalamazoo Code of Ordinance states:

Historical preservation is a public purpose. To serve that purpose, the Historic District Commission is hereby charged with the following responsibilities:

- a) The Kalamazoo Historic District Commission is empowered to regulate Work on the exterior of historic resources and non-historic resources in historic districts in the City of Kalamazoo and shall otherwise have all powers invested in Historic District Commissions pursuant to the Local Historic Districts Act, MCLA § 399.201 et seq. 1970 PA 169, as Amended 1992.
- b) To regulate Work on resources which, by City ordinance, are historic or non-historic resources located within local historic districts, including but not limited to the moving of any structure into or out of, or the building of any structure in, an historic district.

The following documents are available in the Community Planning and Economic Development Department located at 245 North Rose Street. These documents will help assist property owners in understanding the responsibilities of owning property in a local historic district: MCLA § 399.201 et seq. 1970 PA 169 as Amended 1992 (Michigan Local Historic District Act); Code of Ordinances City of Kalamazoo, Michigan (Chapter 16 - Historic District); Secretary of the Interiors Standards for Rehabilitation & Guidelines for Rehabilitating Historic Buildings, 1990; Standards and Guidelines for Kalamazoo Historic Districts, and maps of Kalamazoo Local Historic Districts. These documents and maps are also available on the city of Kalamazoo website at www.kalamazoocity.org/historicpreservation.

GUIDELINES FOR PUBLIC PARTICIPATION AT HDC MEETINGS

The Historic District Commission recognizes that citizens who make the effort to attend a Commission meeting often feel passionately about an issue. The following guidelines are not meant to discourage individual expression; rather, they exist to facilitate the orderly conduct of business and to ensure that all citizens who wish to address the Historic District Commission are able to do so in an atmosphere of civility and respect.

- Out of respect for business being conducted during the meeting, turn off all cell phones and pagers prior to the meeting.
- Citizens have opportunities to address the Historic District Commission at the following times during a meeting:
 - Address Non-agenda items at the beginning of the meeting. If you wish to speak about a specific review, please wait until that review comes to the commission.
 - Consideration of Regular Agenda items. Citizens are permitted to speak to the Commission on project reviews after the applicant has made their presentation and prior to the Historic District Commission discussion. The Chair will call for comments from the public.

A Note on Quorum and Historic District Commission Decisions

City of Kalamazoo Code of Ordinance – Chapter 16 – Historic District Commission – section 19 states: “A majority of the members of the Commission shall constitute a quorum. A majority of the appointed members is required to take action on all matters not of an administrative nature, but a majority of a quorum may deal with administrative matters.” All applicants should be aware that the minimum of four of the commissioners must vote for a motion for a decision to be made in all actions. Applicants may choose to postpone their review to the next regularly scheduled meeting of the commission before the commission begins their deliberations if fewer than seven commissioners are present. The postponement form is available from the coordinator and must be filled out and signed before the applicant leaves the meeting.

KALAMAZOO HISTORIC DISTRICT COMMISSION

Agenda – Tuesday, May 19th, 2026

5:00 pm

241 W. South St. Kalamazoo, MI 49007

I. Call to Order: Mr. Kastner called the meeting to order at 5:00 PM

II. Roll Call & Approval of Absences:

Katie Boertman- Present
Dana Underwood – Present
James Johnson-Present
Dan Kastner- Present
Kristi Breisach- Present
Nelson Nave- Present

All commissioners present

Mr. Pena read the disclaimer on record at 5:02 PM.

III. Approval of Agenda:

Motion made to approve agenda by Mr. Boertman with a 2nd by Mr. Nave. All commissioners approve.

IV. Approval of Minutes: April 21st, 2026

Motion made to approve the minutes by Mr. Johnson with a 2nd by Mr. Nave

V. Public Comment on non-agenda items: No guests and no public comments.

VI. OLD BUSINESS: None

NEW BUSINESS:

A. 703 S Park st

Year Built: 1900

**Alteration: Removal of deck,
Construction of new deck
Style: Colonial Revival
Historic District: South St- Vine
Area**

Mr. Mike Purwin is the owner and is looking to remove an existing deck and replace it with a new deck with a smaller footprint. Mr. Purwin wants to have a space for his tenants to use for grilling

and relaxing. Mr. Pena is unsure if the structure is original to the home based on maps and records. The current deck is in bad shape. The new size proposed does seem more appropriate. Mr. Purwin believes the porch has been painted in the past and has had stairs replaced. Mr. Pena does state that based on records the style of the home does show two different styles. If the deck does move forward, a future owner could remove the deck and build back the enclosed porch. The current porch is 4x6 and the new plan shows the new deck to be 9x6. Mr. Purwin does state that he would be willing to make the length short with the max length being 9 ft. Ms. Breisach wants to know what the bottom of the deck would look like, would be deck posts not skirting and the deck would be made from either cedar, redwood or treated lumber. Ms. Underwood makes a motion to approve a Certificate of Appropriateness for the work described in the application to demo the existing porch and repair damage from demo with appropriate materials and replace it with a deck no greater than 6x9; the proposed work complies with the Secretary of the Interior standards 2, 6 and 9 with a second by Mr. Johnson. The motion passes with 4 voting yes and Mr. Nave and Ms. Breisach voting no.

B. 830 W Vine St

Year Built: 1875

**Alteration: Replacement of
Basement egress window**

Style: Italianate

**Historic District: South Street-
Vine Area**

The applicant wants to replace an egress window. The window is in the basement and is currently broken. The window is not visible from the street. Mr. Nelson is curious about whether someone can get out of the window and out of the hole and the homeowner says yes. The new window will have the same dimensions as the current window. The current window is not an original window. The current window is a vinyl window and is changing like to for like. Ms. Boertman makes a motion to approve a Certificate of Appropriateness for the work as described in the application; the proposed work complies with the Secretary of the Interior standards 9 and 10 with a second from Mr. Johnson. 4 commissioners approve with Mr. Nave voting no. Receives majority, so project does get approved.

VII. Action Item

1. HDC Commissioner Application Review

- Mark Dunham- Mr. Dunham introduced himself and gave a brief overview of himself. Mr. Dunham has had experience with the HDC himself from living in the Stuart Neighborhood. Mr. Dunham has used Sandborn Maps with his job as a librarian.
- Elijah Isch- Mr. Isch also introduced himself and gave the commission a brief overview of qualifications, job overview and answering commissions questions with example scenarios.

Ms. Underwood tables the review of the applicants, with a second from Mr. Johnson. All commissioners approve.

Motion by Mr. Johnson to resume discussion with a 2nd from Ms. Boertman. All commissioners approve.

Commissioners discuss applicants.

- Boh are good applicants
- Both live in Stuart Neighborhood
- Have experience renovating in Historic Districts and both are landlords
- Applicant good with public interaction

Ms. Underwood is recommending both applicants, Mr. Dunham and Mr. Isch, be recommended to the City Commissions to join the Historic District Commission. All commissioners approve.

VIII. Coordinator’s Report

- Review of Cases.
- Discussion regarding work that needs to take place on many Historic Houses and how this is monitored by other departments.
- Historic Preservation Awards of Merit

IX. Adjournment

Ms. Kastner adjourned the meeting at 6:46 PM.

Chairperson

Date

Historic Preservation Coordinator

Date

Recording secretary

Date



Historic District Commission Staff Report

City of Kalamazoo

TO: The Kalamazoo Historic District Commission

FROM: Luis Pena, Historic Preservation Coordinator

DATE: June 16, 2026

SUBJECT: 1. 808 W South - Alteration(Replacement of two third floor windows) PHDC26-006

PROPOSED WORK:

From the Description of Work Supplied by the Applicant: Replace two windows on the third floor. The windows are on the east and west side toward the rear of the house. (See application for full description of work).

EVALUATION:

Project Details

Replacement of two vinyl casement windows in the third story of the property (one on the west side, one on the east side, of the property). The proposed replacement windows will be smaller than the existing casement windows, and will be double hung, wood windows.

Applicable Criteria

Secretary of the Interior's Standards for Rehabilitation

2. The historic character of a property shall be retained and preserved. The removal of historic materials or alteration of features and spaces that characterize a property shall be avoided.

The windows slated for replacement are not original to the property, and do not contribute to the character of the property.

6. Deteriorated historic features shall be repaired rather than replaced. Where the severity of deterioration requires replacement of a distinctive feature, the new feature shall match the old in design, color, texture, and other visual qualities and, where possible, materials. Replacement of missing features shall be substantiated by documentary, physical, or pictorial evidence.

The windows slated for replacement are not historic, as noted above.

9. New additions, exterior alterations, or related new construction shall not destroy historic materials that characterize the property. The new work shall be differentiated from the old and

shall be compatible with the massing, size, scale, and architectural features to protect the historic integrity of the property and its environment.

The proposed windows will not destroy any materials that characterize the property. The new windows will be differentiated from old windows as they are modern in construction (double paned, modern jamb liners, modern hardware). The windows will, however, be compatible with the massing, size, scale and architectural features of the property.

10. New additions and adjacent or related new construction shall be undertaken in such a manner that if removed in the future, the essential form and integrity of the historic property and its environment would be unimpaired.

The proposed windows could be removed in the future without impairing the historic character of the property.

Local Historic District Standards and Guidelines

Windows:

- The dimension of the original window must be retained.
 - *The windows slated for replacement are not original to the house. The dimensions will be altered.*
- Muntins, sash, frames, exterior casing and brick molds must be of material and dimensions to match other windows in the house.
 - *There are a variety of window sizes and styles on the house. The proposed double hung windows with top grills will pull elements from windows throughout the house.*
- Aluminum and vinyl clad windows do not meet the above requirements. Vinyl plastic windows are not acceptable because they are made of non-historic materials and do not comply with the Secretary of the Interior's Standards for Rehabilitation. (CLICK to Secretary of the Interior's Standards on this website).
 - *The proposed windows are wood.*
- Metal windows may be considered for some applications, such as basement windows if they match the dimensions of the original windows.
 - *N/A*
- Decorative materials such as Palladian, oriel, bay, Gothic, round or segmental top cannot be removed.
 - *N/A*

Discussion

POTENTIAL ACTIONS:

1. The proposed work complies with the Secretary of the Interior standards 2, 6, 9 and 10. **Action: Motion to approve a Certificate of Appropriateness for the work as described in the application.**
2. More information is needed. **Action: Motion to postpone until the HDC meeting on 21 July 2026 and direct the applicant to provide the requested materials and information to the Historic Preservation Coordinator by noon on 14 July 2026.**
3. Denial of the application. **Action: Motion to deny the application based on Secretary of the Interior Standards 2, 6, 9 and 10.**



Community Planning and Economic Development
 Historic District Commission
 245 N. Rose Street
 Kalamazoo, MI 49007
 Telephone: (269) 337-8804; FAX (269) 337-8513
Penal@kalamazoo-city.org

APPLICATION FOR PROJECT REVIEW – Administrative review

(PLEASE PRINT CLEARLY - See instructions on reverse side)

Property Address: 808/810 W. South St.

Historic District: South/Vine Stuart West Main Hill Rose Place Haymarket

Applicant: Chris Horvut Owner: same

Mailing Add: 810 W South St. Mailing Add: _____

City State & Zip: Kal. Mi. 49007 City, State Zip: _____

Phone: 972/757-6777 Phone: _____

Email: cgh52@yahoo.com Email: _____@_____

Contractor: _____

Work to be done by owner

Contractors name: _____

Proposed Work: (Use additional sheets to describe work if necessary)

see notes!

This property has at least one working smoke detector for each dwelling unit.
 (Owner or applicant's initials, required) * see back

Applicant's Signature: [Signature] Date: 5-22-26

Owner's Signature: _____ Date: _____
 (if different)

-For Historic Preservation Coordinator's Use Only-

Case Number PHDIC 26-006 Date Received 05-22-2026

Zoning RM15 YEAR BUILT 1915 Complete application yes

Owned since 05/08/1996 Fee Paid \$35

- This project will require a building permit with a \$35 administrative review fee.
- This project will not require a building permit. There are no fees for this project
- Referred to the Historic District Commission for review at a monthly hearing - \$85 hearing fee.
 Meeting date 16 June 2026

ADMINISTRATIVE

Staff Review Date _____ Approve Site Visit Approve w/Conditions

COMMENTS

 Certificate of Appropriateness Issued _____
 Notice to Proceed _____

Referred to Historic District Commission for hearing* yes \$85
 fee Hearing date 16 June 2026

Application Checklist:

- Drawings 11x17 or smaller with dimensions
- Materials list
- Site plan including north arrow
- Other

- \$35 - HDC review fee – charged with building permit

I plan to replace two windows on the third floor. The windows are on the east & west side toward the rear of the house.

The east facing window is a casement replacement that was installed 35-40 years ago. This window cannot be opened as it is falling apart.

I will use a double hung window with an upper grid. The new window will be slightly less wide and will look more appropriate historically.

The west facing window (also a casement) another replacement window has become difficult to open & close due to warping.

I will replace this window with a double hung with an upper grid. This window will be less wide & a bit shorter to accommodate room inside for a kitchen counter.

Existing casement to be replaced

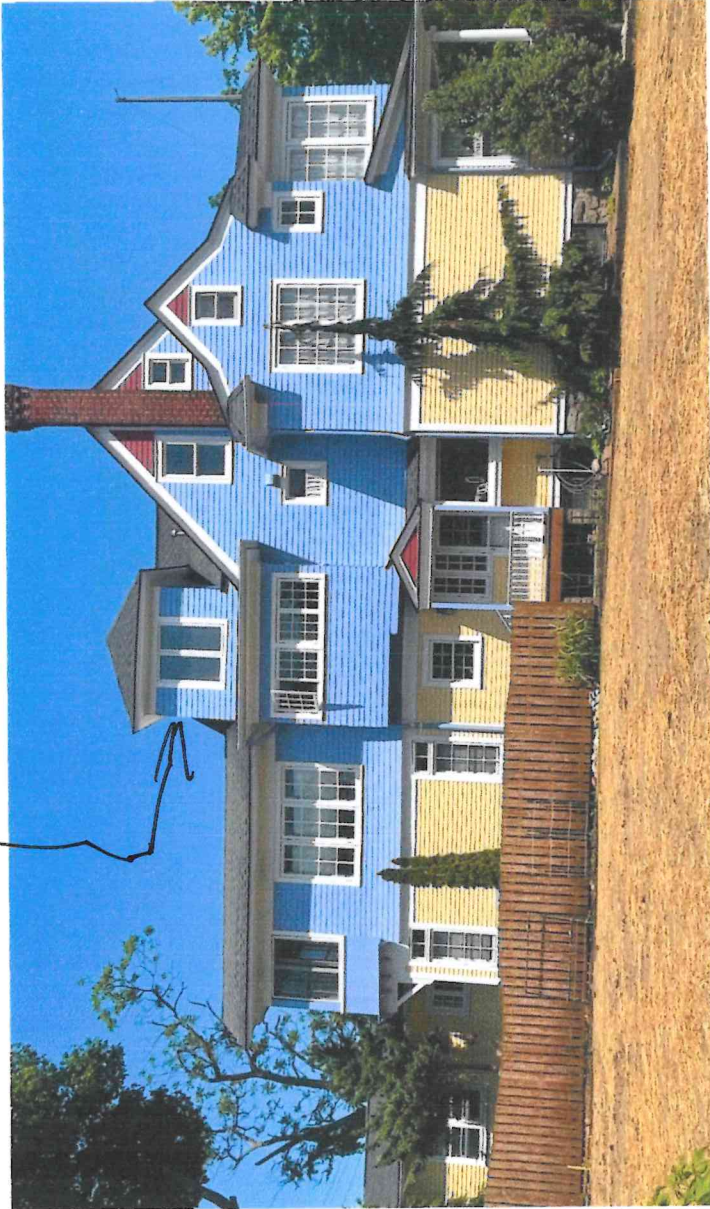

Shows west side
East side is typical



EIKENHOUT INC. - KALAMAZOO

5669 E CORK ST

KALAMAZOO MI 49048

Phone: 269-366-3280 Fax: 616-459-4051

Customer Quote

Short Form

QUOTE EXPIRES

N/A

QUOTE DATE

Quote Not Ordered

BID BY

PRICE BOOK

Price Book 2026

CREATED

5/15/2026

mheuring@eikenhout.com

PK # 334

Customer Information:

Phone: Fax:

Delivery Information:

Phone: Fax:

QUOTE #	STATUS	CUSTOMER PO#	DATE PRINTED
3162551	None		5/15/2026 12:08 PM
CUSTOMER JOB NAME	TERMS	QUOTE NAME	PROJECT NAME
		Chris Horvat 972-757-6777	Kalamazoo Contractors

Line #	Room ID	Overall RO	Overall Frame	Price	Qty	Extended
100	None Assigned	32 1/32" X 41 1/4"	31.275" X 40.75"	\$889.65	2	\$1,779.30

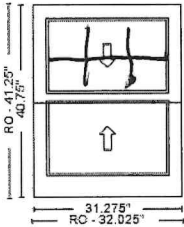

Pinnacle Wood Prime Double Hung XXXX-1 Complete Unit Dual Low-E IG 4-9/16 Jamb Ext (Setup (Standard))(Glass Stop Profile: Ogee)(FD: 31.275 x 40.75)(Pine Species)(White Paint)(No Finger Pulls)(Grey Spacer)(White Jambliner)(White Hardware)(No Brickmould)(No Sill Nosing)(Full Screen)(White Screen - Not Applied)(BetterVue)(Performance Upgrade)(Energy Star: Meets in NC, SC, S Zones)(LC-PG50-H) Performance Data:(U-Value: 0.24)(SHGC: 0.19)(VT: 0.45)(CR: 49)

* Units viewed from exterior.

west window



EIKENHOUT INC. - KALAMAZOO

5669 E CORK ST

KALAMAZOO MI 49048

Phone: 269-366-3280 Fax: 616-459-4051

Customer Quote

Short Form

QUOTE EXPIRES

5/21/2026

QUOTE DATE

Quote Not Ordered

BID BY

PRICE BOOK

Price Book 2026

CREATED

5/21/2026

mheuring@eikenhout.com

PK # 336

Customer Information:

Phone: Fax:

Delivery Information:

Phone: Fax:

QUOTE #	STATUS	CUSTOMER PO#	DATE PRINTED
3164335	None		5/21/2026 11:04 AM
CUSTOMER JOB NAME	TERMS	QUOTE NAME	PROJECT NAME
		Chris Horvat	Kalamazoo Cash Contractor

Line #	Room ID	Overall RO	Overall Frame	Price	Qty	Extended
100	None Assigned	36 1/8" X 49 1/4"	35.375" X 48.75"	\$923.92	1	\$923.92

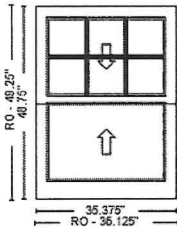

Pinnacle Wood Prime Double Hung 3020-1 Complete Unit Dual Low-E IG 5-1/4 Jamb Ext (Setup (Standard))(Glass Stop Profile: Ogee)(Callout:2-10 x 3-10)(Pine Species)(Primer)(No Finger Pulls)(Grey Spacer)(Beige Jambliner)(White Hardware)(No Brickmould)(No Sill Nosing)(5/8" Putty WDL Short w/Inner Bar)(Putty WDL Interior Profile)(Colonial Pattern 3W2H/No Grilles Bottom Sash)(Full Screen)(White Screen - Not Applied)(BetterVue) (Energy Star: Meets in NC, SC, S Zones)(LC-PG35-H) Performance Data:(U-Value: 0.24) (SHGC: 0.17)(VT: 0.4)(CR: 49)

* Units viewed from exterior.

East window

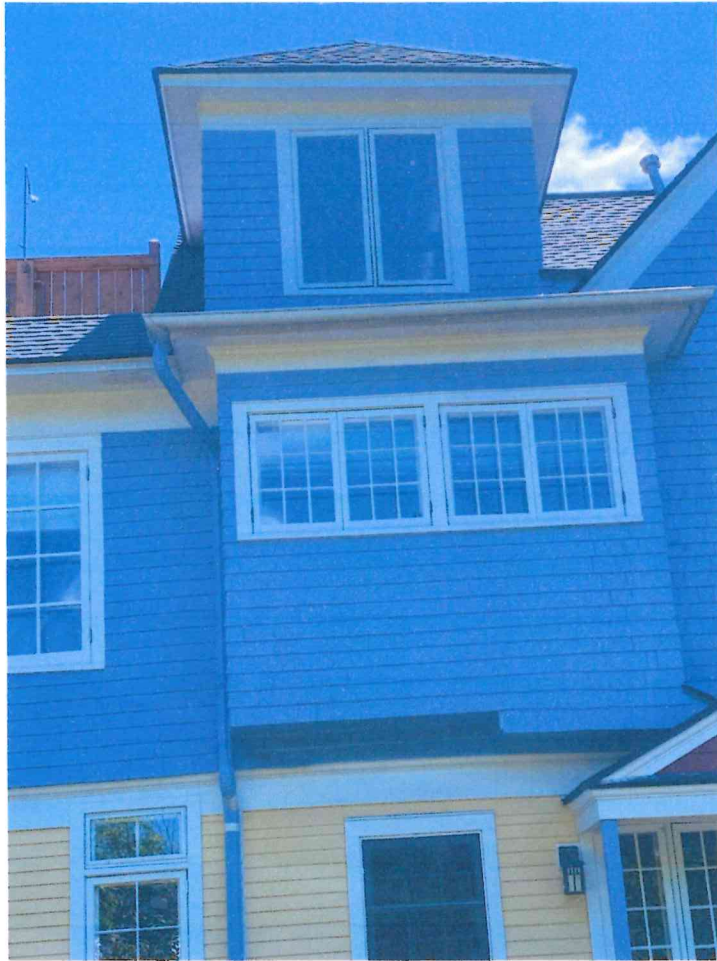

RECEIVED

JUN 12 2026

JS

West window
810 W South St

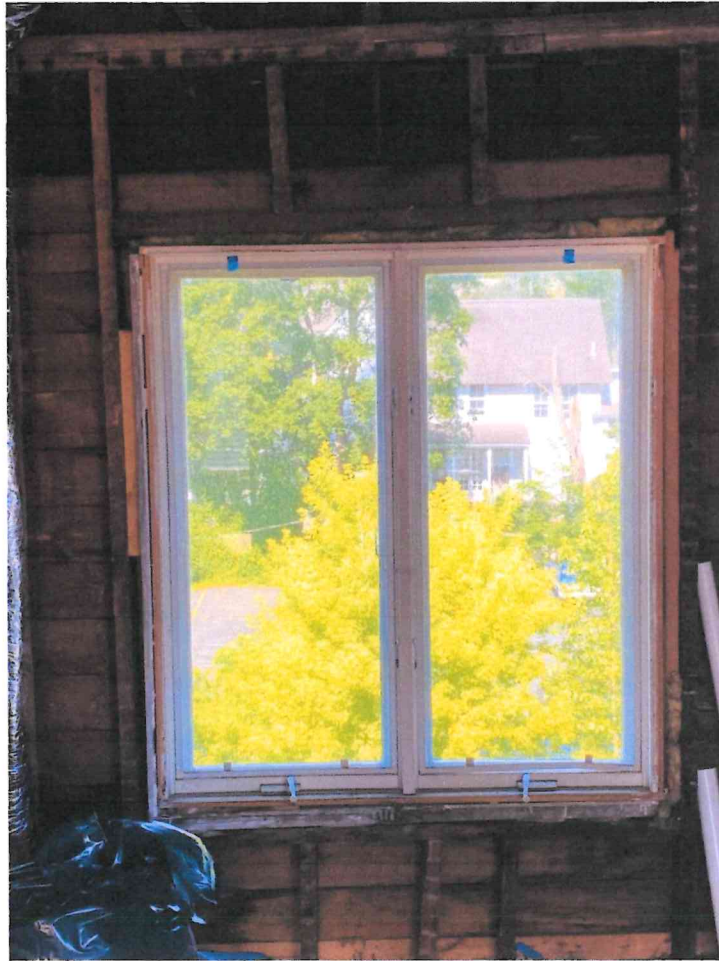

West window inside

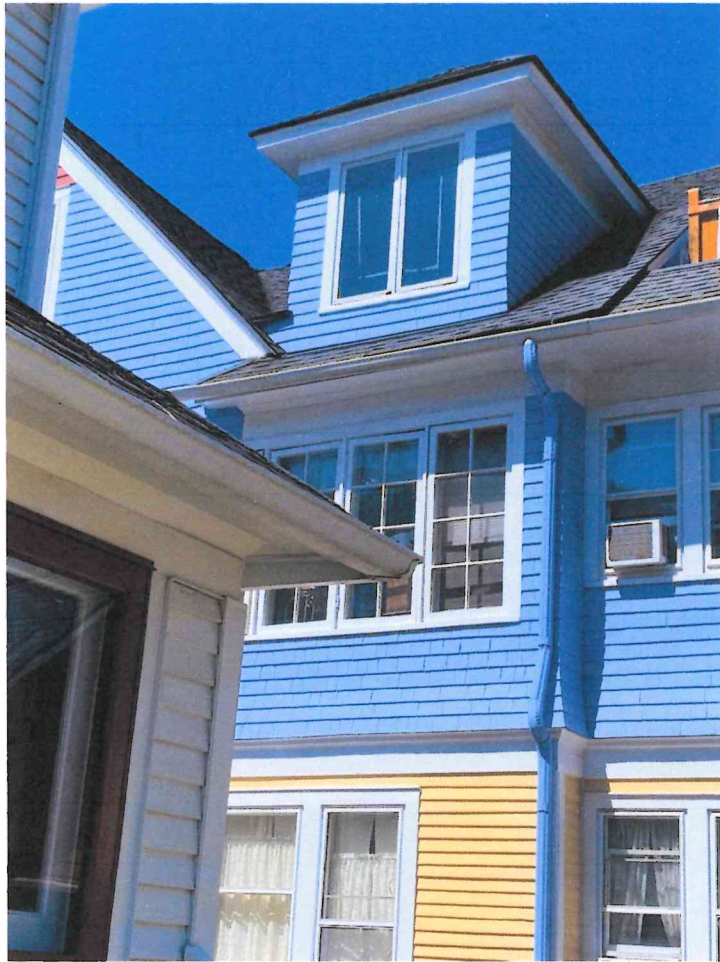

East window

810 W. South St

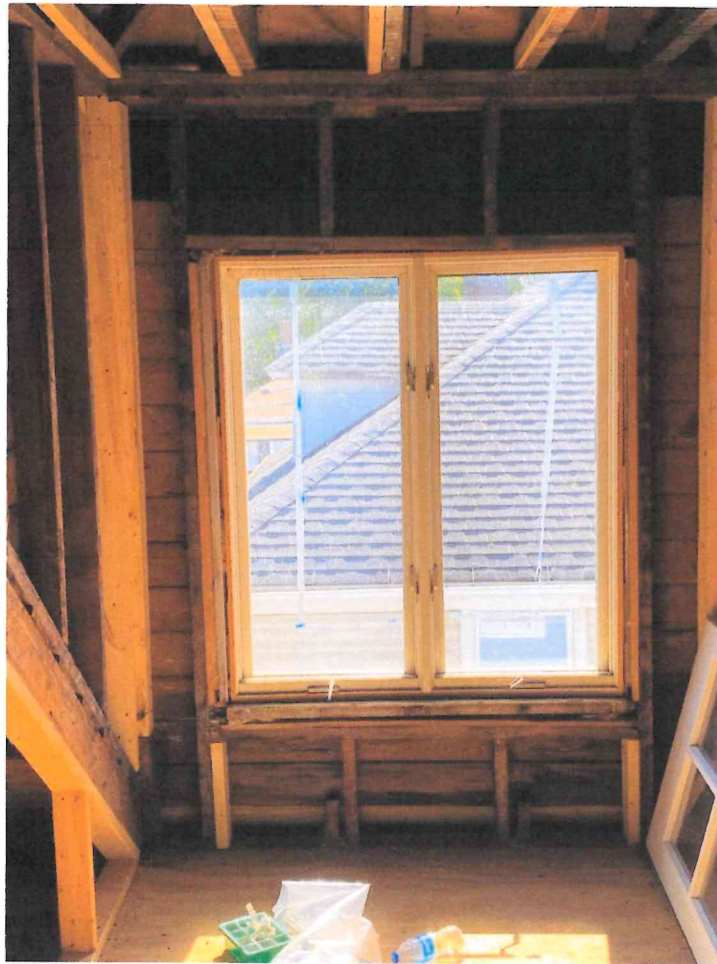

· East window
completely non-functioning



Historic District Commission Staff Report

City of Kalamazoo

TO: The Kalamazoo Historic District Commission

FROM: Luis Pena, Historic Preservation Coordinator

DATE: June 16, 2026

SUBJECT: 2. 613 Douglas - Alteration (installation of barrier free ramps on the front and rear of the property) PHDC26-007 *Retroactive Review*

PROPOSED WORK:

From the Description of Work Supplied by the Applicant: Installation of two exterior wheelchair accessibility ramps from pressure treated lumber. Front entrance and side entrance. Required for AFC licensing compliance (R400.651) No plumbing, electrical involved.

EVALUATION:

Project Details

Construction of two wheelchair ramps on the property. One on the front (East) face of the building, the other on the rear (north/west) face of the property. The ramp added on the front (east face) of the property could be built over an existing porch. It appears that the rear (north/west) ramp could also be built over the existing porch.

Applicable Criteria

Secretary of the Interior's Standards for Rehabilitation

9. New additions, exterior alterations, or related new construction shall not destroy historic materials that characterize the property. The new work shall be differentiated from the old and shall be compatible with the massing, size, scale, and architectural features to protect the historic integrity of the property and its environment.

Both the front (east) and rear (north/west) porches on the property could remain and have the proposed ramps be built over them. The proposed porches could be built from new materials, relatively free of ornamentation to differentiate the ramps from the historic structure. The size, massing, and scale could still be compatible with the historic structure to to protect the historic integrity of the property and the environment.

10. New additions and adjacent or related new construction shall be undertaken in such a manner that if removed in the future, the essential form and integrity of the historic property and its environment would be unimpaired.

If the proposed ramps were built over the existing porches at the property, the proposed ramps could be removed in a way that left the essential form and integrity of the historic property and its environment unimpaired.

Local Historic District Standards and Guidelines

Barrier Free Access Ramps:

All ramp designs must be reviewed by the full commission.

Preferably, ramps will be placed at the rear or as unobtrusively as possible on the side of the structure. For example, if the only possible location for a ramp is at the front, its impact can be minimized with the use of pipe rail for the sides instead of a rail using balusters like a porch rail.

The proposed ramps will be on the front (east) and rear/side (north/west, respectively) of the property. Pipe rails are not proposed on the front of the property, porch like balusters are proposed.

If a portion of the porch rail must be removed to allow the ramp to be attached, that piece of rail shall be preserved and stored on the premises in a protected environment to allow for its preservation and possible restoration at a later date. (Sometimes the removed rail can be stored under the porch, hanging from large storage hooks attached to the frame.)

It is unclear from the drawings whether or not porch railings will need to be removed for the installation of the proposed ramps.

A barrier free ramp should be designed to be removable with minimal impact on the historic structure.

It appears, as noted above, that the ramps could be installed over the existing porches, which would allow for minimal impact upon removal.

Discussion

The proposed porches could be installed in a way that would not damage historic features of the property. Additionally, the proposed porches could be installed in a way left the historic structure unimpaired if removed in the future. The proposed ramps should be painted after installation.

POTENTIAL ACTIONS:

1. The proposed work complies with the Secretary of the Interior standards 9 and 10. **Action: Motion to approve a Certificate of Appropriateness for the work as described in the application.**

2. More information is needed. **Action: Motion to postpone until the HDC meeting on 21 July 2026 and direct the applicant to provide the requested materials and information to the Historic Preservation Coordinator by noon on 14 July 2026.**

3. Denial of the application. **Action: Motion to deny the application based on Secretary of the Interior Standards 9 and 10.**



RECEIVED
MAY 19 2026

Community Planning and Economic Development
Historic District Commission
245 N. Rose Street
Kalamazoo, MI 49007
Telephone: (269) 337-8804; FAX (269) 337-8513
Penal@kalamazoo.org

APPLICATION FOR PROJECT REVIEW – Administrative review

(PLEASE PRINT CLEARLY - See instructions on reverse side)

Property Address: 611 1/2 Douglas Ave Kalamazoo MI 49007
Historic District: South/Vine Stuart West Main Hill Rose Place Haymarket
Applicant: Linda Dixon-Jones Owner: Linda Dixon-Jones
Mailing Add: PO BOX 151 Mailing Add: PO BOX 151
City State & Zip: Nazareth, MI, 49074 City, State Zip: Nazareth, MI, 49074
Phone: 269 501 0649 Phone: 269 501 0649
Email: Lindadixonjones@gmail.com Email: Lindadixonjones@gmail.com

Contractor: _____
 Work to be done by owner
 Contractors name: _____

Proposed Work: (Use additional sheets to describe work if necessary)

Installation of two exterior wheelchair accessibility ramps from pressure-treated lumber. Front entrance and side entrance. Required for APC licensing compliance (R 400.651) No plumbing, electrical involved.

This property has at least one working smoke detector for each dwelling unit.

(Owner or applicant's initials, required) * see back

Applicant's Signature: Linda Dixon-Jones Date: 4/22/2026

Owner's Signature: _____ Date: _____
(if different)

-For Historic Preservation Coordinator's Use Only-

Case Number PHDC 26-067 Date Received 05/19/2026
Zoning LW1 YEAR BUILT 1957 Complete application yes
Owned since 11/27/2018 Fee Paid \$35

- This project will require a building permit with a \$35 administrative review fee.
- This project will not require a building permit. There are no fees for this project
- Referred to the Historic District Commission for review at a monthly hearing - \$85 hearing fee.
Meeting date 16 June 2026

ADMINISTRATIVE

Staff Review Date _____ Approve Site Visit Approve w/Conditions
COMMENTS

Certificate of Appropriateness Issued _____
Notice to Proceed _____

Referred to Historic District Commission for hearing* yes \$85
fee Hearing date 16 June 2026

Application Checklist:

- Drawings 11x17 or smaller with dimensions
- Materials list
- Site plan including north arrow
- Other

\$35 - HDC review fee - charged with building permit

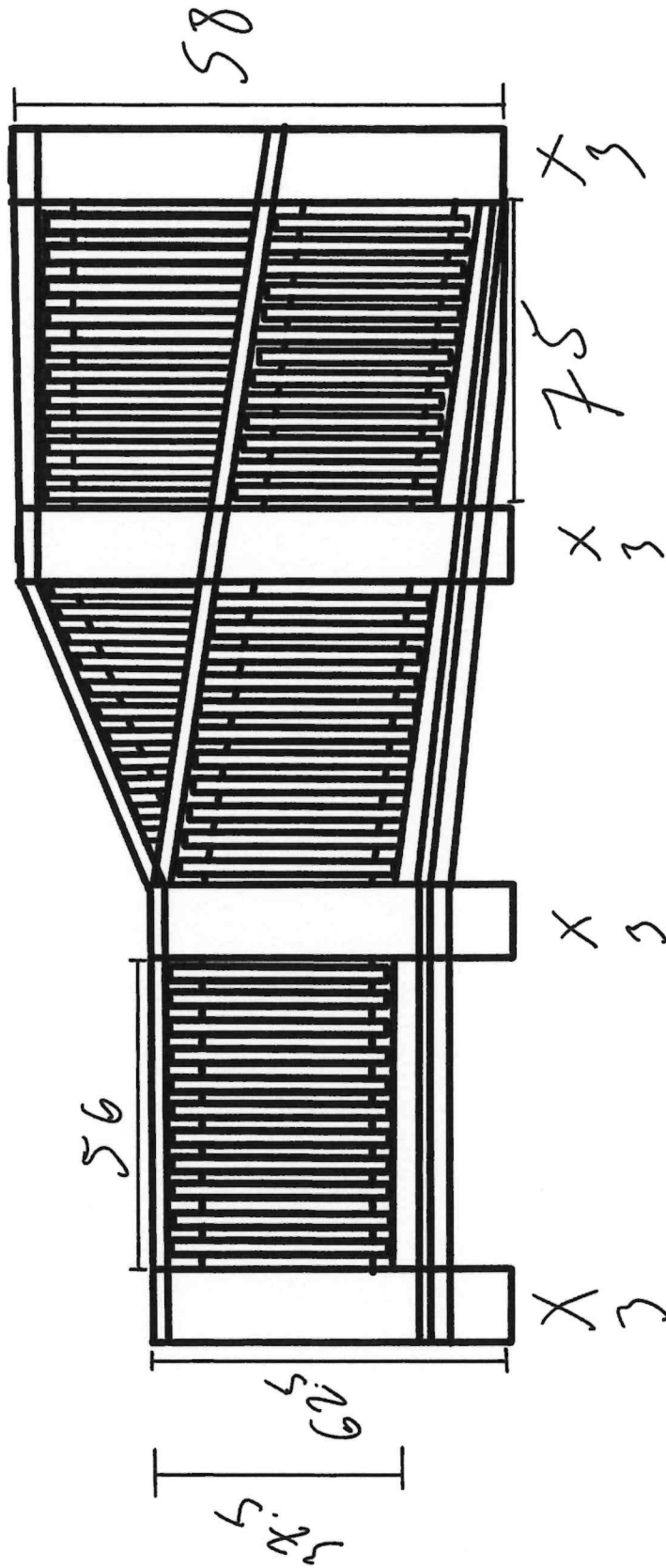

Back lateral

All measurements in inches

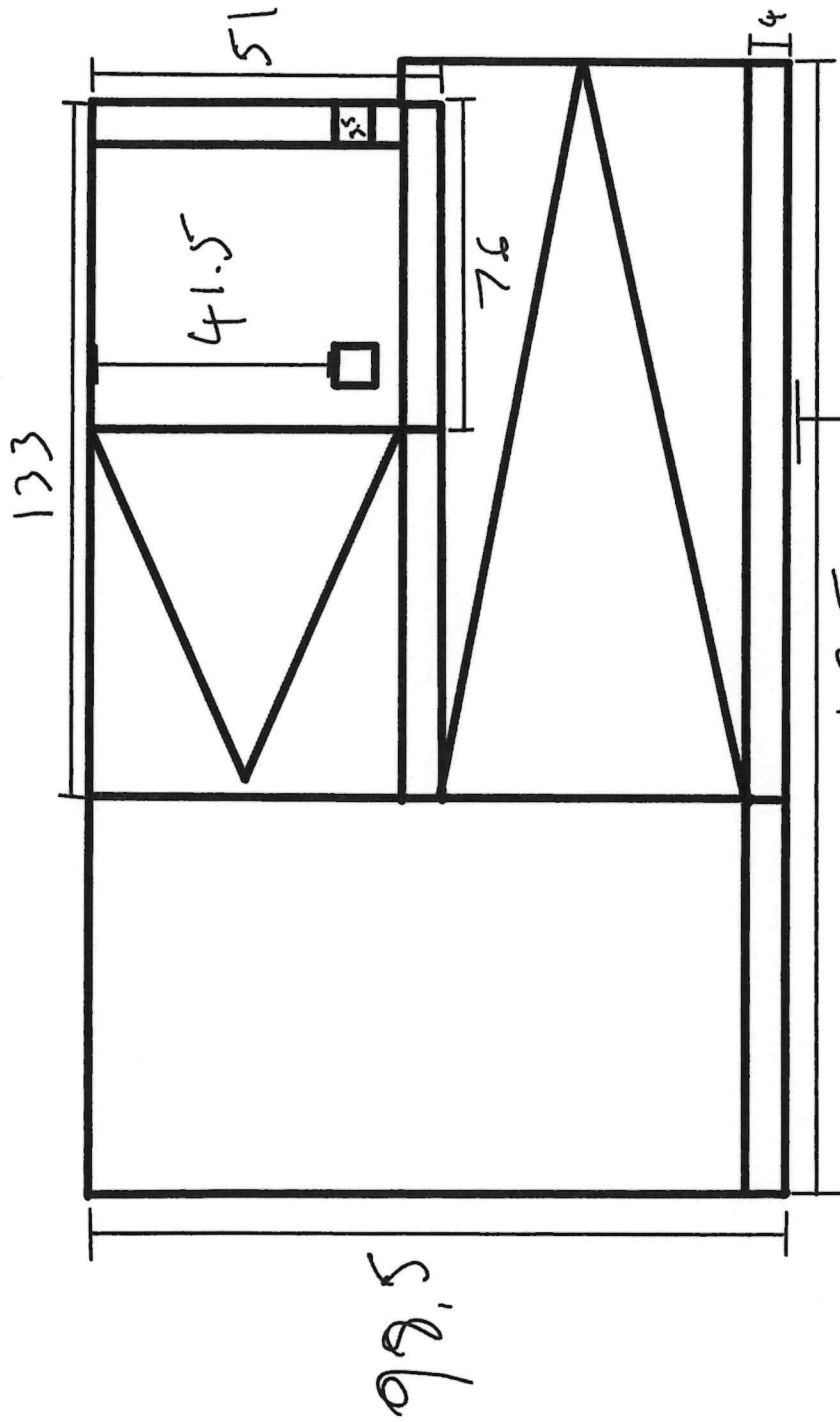

Back top

231

Property
end

All measurements in inches

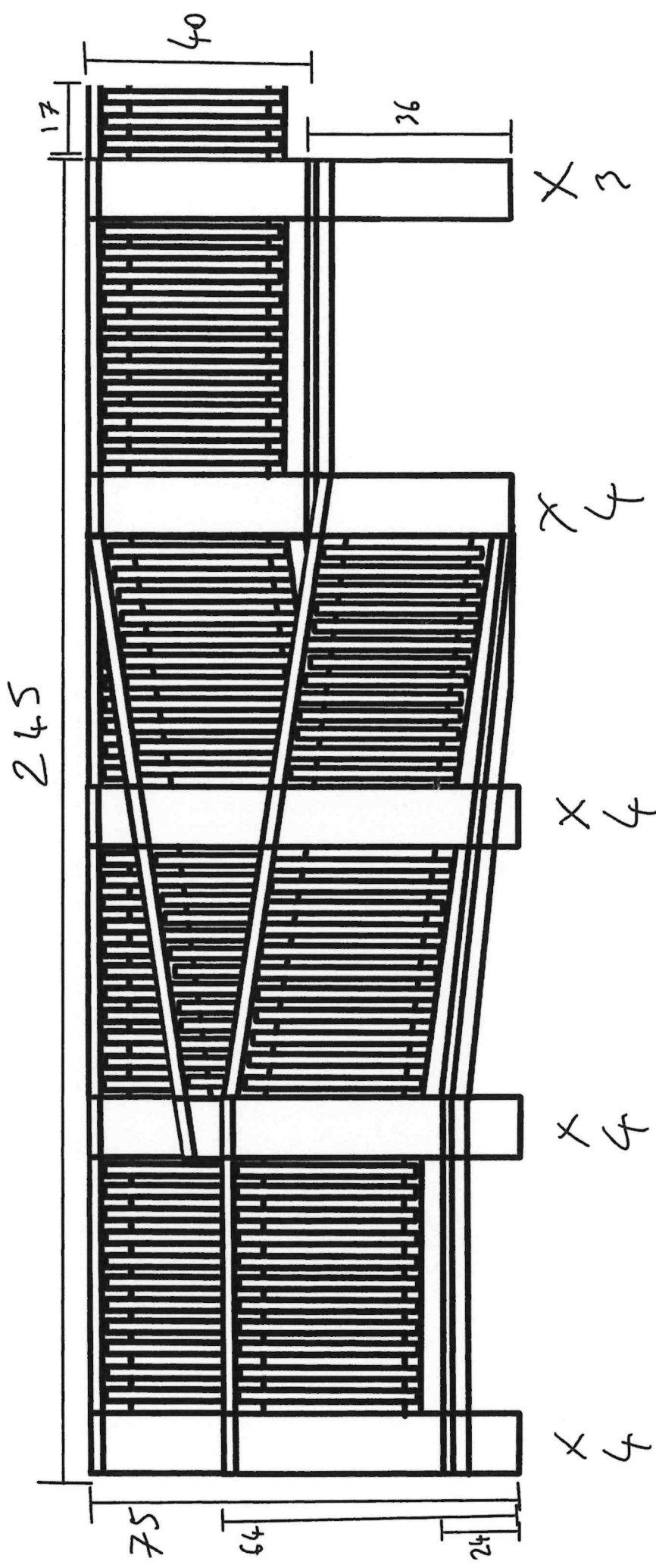

front labeled

All measurements in inches

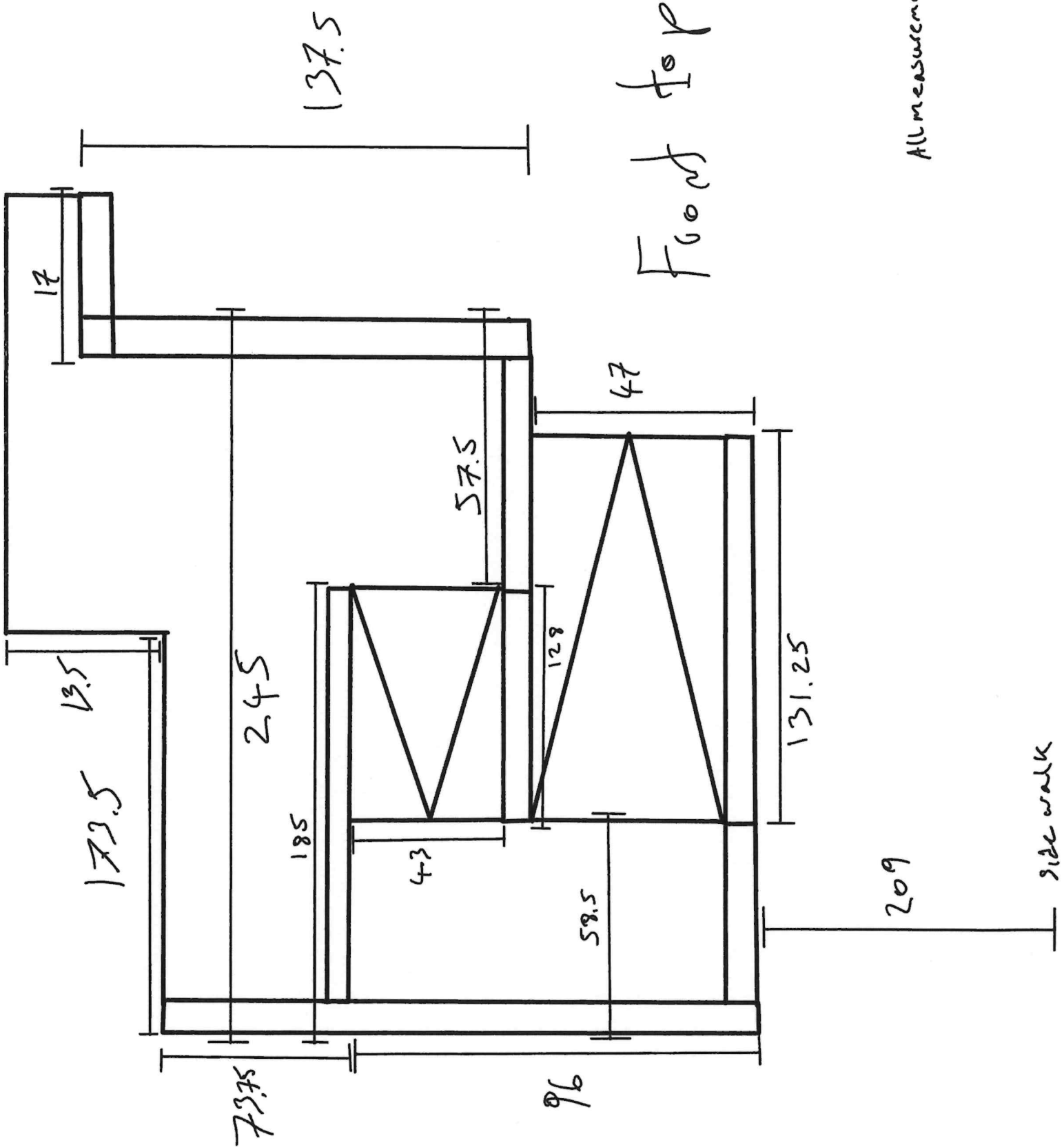

All measurements in inches







FOR RENT
CALL TERRY
781-888-1234



Historic District Commission Staff Report

City of Kalamazoo

TO: The Kalamazoo Historic District Commission
FROM: Luis Pena, Historic Preservation Coordinator
DATE: 16 June 2026
SUBJECT: Historic Preservation Coordinator's Report

Historic District Reviews

Review Type	Cost	Number of Reviews	Totals
Administrative	\$35	23	\$805
Hearing	\$85	6	\$510
		29	\$1,315

Administrative Reviews:

936 W Lovell – Rear step rebuild
813 Normal Ct – Reroof
615 Minor Ave – Storm Door
932 W Lovell - Gutters

Community Planning and Economic Development Department | 245 N. Rose Street, Ste 100, Kalamazoo, MI 49007
Voice: (269) 337-8744 | Fax: (269) 337-8513 | www.kalamazoocity.org